

CONEMAUGH TOWNSHIP AREA ELEMENTARY SCHOOL STUDENT HANDBOOK

Mr. T. J. Kakabar, District Superintendent

Mrs. Nicole Dull, Elementary Principal



2021-22 SCHOOL YEAR

Distributed 8-25-2021

BE BRAVE DON'T BULLY

- WE will NOT bully others.
- We will try to help students who are being bullied.
- We will include students who are left out.
- When we know someone is being bullied, we will tell an adult at school and at home.



Mission Statement	10
Nondiscrimination Policy	10
Title 1/ESSA Act of 2015	11-15
Academic/ Conduct Evaluation	16
Admission of Beginners	17
Alternate Home	17
Animals / Pets	17
Attendance	17-18
Birthdays	19
Breakfast and Lunch Programs / Lunch Charges	19
Building and Classrooms	19
Bus Riding / Bus Rules /Bus Surveillance/ Bus Stops	19-21
Cafeteria Behavior	21
Criminal Acts on School Property	21
Disciplinary Measures	21
Dress Code	22
Drug, Alcohol, and Tobacco Use Policy	23
Elementary Instrumental and Vocal Music Program	23
End-of-the Day Pick-up (Dismissal time)	24
Field Trips	24
Firearms/Weapons Policy	24
Fundraising	25
General Behavior	25
Guidelines for School Discipline of Exceptional Students	25
Hearings	26
Homework	26
Honor Roll / Principal's Improvement Club (PIC)	26-27
Instructional Support	27
Internet / Technology Resources	27
Library Use	27
Make-up Work	27-28
Mentally Gifted Procedures	28-29
Olweus Program	29
Open-Door Policy / Parent-Teacher Communications	29
Opening Exercises/ Flag Salute	30
Party Invitations	30
Personal Property, Money and Valuables	30
PowerSchool	30
Public Access to School Property / School Security	30
Publications	30
Recess	30
Registration	31
Report Cards	31
Requests to be Excused	31
Responsibilities of Students	31-32
Responsibilities of Parents	32
Retention Policy	32

School Day/Cancellations, Delayed Openings, or Early Dismissals	33
School Security	33
Sexual Harassment (Unlawful Harassment)	33
Smoking and Tobacco Policy	33-34
Snacks	33
Special Education Regulations/ Chapter 14	34-36
Student Accident Insurance	36
Student Assistance Program (SAP)	36
Student Emergency Card	36
Student Guests	36
Student Records	36
Suspension of Students	36-37
Take Your Child to Work Day	37
Tardiness	37
Teacher Requests...	38
Withdrawal from School	38
Wellness Policy	38-39
General Health / HIV/AIDS	39
Medication	39-40
Prevention and Treatment of Head Lice and Lice/Nit Free Procedure	41
Covid-19 Health Information	42
Floor Plans for the Elementary School	43
Disciplinary Structure - Student Misconduct/Response	44-48
Acceptable Use Policy	49-50
Educational Trip Form	51-52

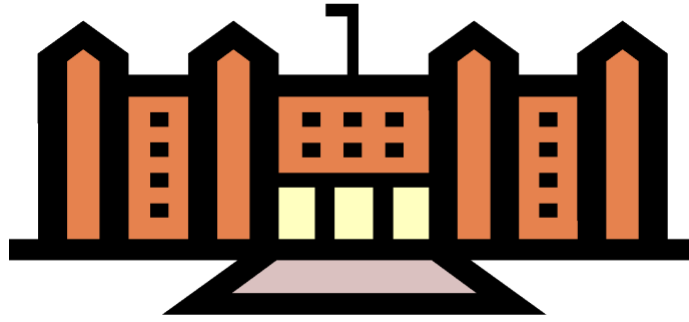

SCHOOL BOARD OF DIRECTORS

President
Vice President
Secretary
Treasurer
Members

Mrs. Christine Troxell
Dr. Rocco Mantini
Mr. Earl Sleek, II
Mr. Jeffrey Alesantrino
Mrs. Melanie Byer
Mrs. Susan Saylor-Stahl
Mrs. Michelle Stumpf
Mr. Alan Tresnicky
Mr. Justin Zahorchak

The Conemaugh Township Area School District conducts its committee and school board meetings on the second Monday and the third Tuesday of each month respectively.

All committee and board meetings are open to the public.

ADMINISTRATION

Superintendent
Business Manager/Director of Transportation
Food Service Director
Building and Grounds Supervisor
High School Principal
Assistant High School Principal / Athletic Director
Elementary Principal
Special Education Coordinator
Curriculum Director

Mr. T. J. Kakabar
Mrs. Regina Rembold
Mr. Adam Thomas
Mr. Alan Zimmerman
Mr. James Foster
Mr. Jarod Feathers
Mrs. Nicole Dull
Mrs. Jane Jugan
Mrs. Stacy Dabbs

**CONEMAUGH TOWNSHIP AREA SCHOOL DISTRICT ELEMENTARY STAFF
2021-2022 SCHOOL YEAR**

Secretary	Mrs. Kimberly Meyers		Third Grade	Mrs. Lorrie Callihan
Secretary	Mrs. Rose Thomas			Mrs. Kelly Digon
Guidance Counselor	Mrs. Erin Stroz			Mrs. Audrey Wenger
Special Education Director/School Psych.	Mrs. Jane Jugan			
School Nurse	Mrs. Karen Cascino		Fourth Grade	Mrs. Jacqueline Feathers
Curriculum Director	Mrs. Stacy Dabbs			Mrs. Megan Miller
				Mrs. Alyshia Mock
Kindergarten	Miss Ruth Hostetler			
	Mrs. Becky Lough		Fifth Grade	Mrs. Rebecca Conn
	Mrs. Kelly McCall			Mrs. Jamie Kerr
	Mrs. Michele Roman			Mrs. Lori Reese
	Mrs. Amy Stone			
			Learning Support	Mr. Seth Keafer
First Grade	Mrs. Kristy Curry			Miss Korinne May
	Mrs. Christine Magistro			Mrs. Rebecca Parker
	Mrs. Deborah McMillan			Mrs. Wonda Piskuric
	Mrs. Amber Roxby			Mrs. Lisa Style
Second Grade	Mrs. Emily Del Signore			
	Mrs. Ellen Doyle			
	Mrs. Tamelyn McNevin			

**CONEMAUGH TOWNSHIP AREA SCHOOL DISTRICT ELEMENTARY STAFF
2021-2022 SCHOOL YEAR**

Reading Specialists	Mr. Jonathon Waltermire		Aides	Mrs. Fran Bivens
	Mrs. Christine Shroyer			Mrs. Amber Dail
	Mrs. Tammy Williams			Mrs. Monica Matera
				Mrs. Kathryn Williams
STEAM	Mrs. Tammy Williams			Mrs. Sonya Tresnicky
Physical Education	Mr. Jonathon Waltermire			Miss Brenna Weaver
Computer	Mrs. Deborah Mishler			PCA- Ms. Brenda Leverknight
Library/Enrichment	Mrs. Kate Turner			
Music	Mrs. Amanda Evans		Head Cook	Mrs. Keni Miller
	Miss Catherine Kasun		Cafeteria Staff	Mrs. Susan Kolesar
				Mrs. Jean Lawrence
Speech Therapists	Miss Lindsie Hammaker			Mrs. Laura Temyer
	Mrs. Kristen Russo			Mrs. Kimberly Vatavuk
				Mrs. Diane Mulholland
Building Maintenance	Mr. David Budash			Mrs. Kay Kaufman
Custodial Staff	Mrs. Pam Brehm		Americorps Members	Mrs. Cherie Yoder
	Mr. Cody Miller			Mrs. Patty Churchey
	Mr. Matthew Magistro			
	Mr. William Palenik			
	Mr. Brandon Shifflett			



**PTA OFFICERS
2021-2022 SCHOOL YEAR**

<i>President</i>	<i>Mrs. Amanda Tercek (814)244-2934</i>
<i>1st Vice President</i>	<i>Mrs. Jessica Elliott (814)242-7176</i>
<i>2nd Vice President</i>	<i>Mrs. Nicole Dull (814)479-4080</i>
<i>Treasurer</i>	<i>Mrs. Kristi Purdy (814)244-9737</i>
<i>Secretary</i>	<i>Mrs. Allison Endler (814)244-8593</i>

Our PTA meets in the Elementary Library the first Tuesday of the month at 7:00 pm. We work together to provide students and staff with programs, funds and support that make our school the best that it can be. Homeroom parents coordinate holiday party snacks, games, and volunteers. Help is always needed to run fundraisers, assist with special events, and collect donations at concerts. If you are willing to help, please complete the volunteer survey that is distributed at the beginning of the year.



Conemaugh Township Elementary 2020 A National Blue Ribbon School of Excellence

GREETINGS FROM THE PRINCIPAL

Dear Parents/Guardians:

Welcome to the 2021-2022 school year. As we open our doors to students, teachers, staff and families, we will continue to provide everyone with a safe and effective learning environment. A number of staffing and procedural changes have been made to meet the needs of our students and staff. We appreciate your patience and support as we adjust to these changes. As always, your input is important to your child's growth academically and socially. If you ever have a question or concern, please contact his/her teacher directly so that lines of communication can be established in a positive manner.

The purpose of this **Student-Parent Handbook** is to give you a ready reference to our daily school operations. We urge you to read the handbook and to review it with your child. Please contact the appropriate school personnel if you need additional information. Thank you and let's have an enjoyable year!

Warmly,

Mrs. Dull

Mrs. Nicole Dull
Elementary Principal

Conemaugh Township Elementary School
Grades K-5
1516 Tire Hill Road
Johnstown, PA 15905

Telephone: (814) 479-4080
Fax: (814) 479-7497

Please be advised that all incoming and outgoing telephone calls may be recorded.

MISSION STATEMENT (101)

The Conemaugh Township Area School District and community are committed to a student-focused environment that promotes responsibility, encourages respect for self and others, and develops lifelong learning skills while providing opportunities for students to recognize and achieve their potential in meeting the challenges of the future.

Team Township: A Great Place to Grow

**CONEMAUGH TOWNSHIP AREA SCHOOL BOARD
CONEMAUGH TOWNSHIP AREA SCHOOL DISTRICT
NONDISCRIMINATION POLICY
2021-22**

The Conemaugh Township Area School District is an equal opportunity education institution and will not discriminate on the basis of race, color, national origin, sex, and handicap in its activities, programs, or employment practices as required by Title VI, Title IX, and Section 504. The District assures that it will take steps to prevent discrimination or the recurrence of any discrimination and to correct its discriminatory effects on the individual and others, if appropriate. The District further assures all that it will protect those filing complaints or grievances alleging discrimination from harassment and/or retaliation.

For information regarding civil rights, grievance procedures, or activities and facilities that are accessible to and usable by handicapped persons, contact Mr. TJ Kakabar, Title IX and Section 504 Coordinator .

Inquiries should be directed to: Mr. TJ Kakabar, Title IX Coordinator
Section 504 Coordinator
Conemaugh Township Area School District
Davidsville, PA 15928

The following is the annual notification to parents and eligible students of the policies and procedures of the Conemaugh Township Area School District regarding student educational records and rights to parents, surrogate parents, guardians, or eligible students.

In accordance with the Family Education Rights and Private Act and Regulations (34 CRF 99), parents, surrogate parents, guardians, and eligible students are hereby notified of their right to (1) inspect and review educational records: (2) request the amendment of these records to ensure they are not inaccurate, misleading, or otherwise in violation of the student’s privacy or other rights: (3) consent to disclosure of personally identifiable information contained in the student’s educational records, except to the extent the act and the regulations authorize disclosure without consent: (4) file with the U.S. Department of Education a complaint concerning alleged failures by the Conemaugh Township Area School District to comply with the requirements of the act.

If you have any questions or wish to obtain a copy of the Conemaugh Township Area School District’s Guidelines for Collection, Maintenance, and Dissemination of the Student Records, you may call the Conemaugh Township Area School District at (814) 479-4080, or write to:

Mrs. Nicole Dull, Elementary Principal
Conemaugh Township Area School District
Davidsville, PA 15928

EVERY STUDENT SUCCEEDS ACT OF 2015

The *Every Student Succeeds Act of 2015* requires that parents/guardians are notified of the following on an annual basis.

1. Parents/guardians have the **right to inspect all instructional materials and state assessments**. Arrangements should be made in advance with the building principal (Board Policy 105.1 and 127)
2. Parents have the right to **opt out of non-emergency, invasive physical examinations and screenings** as per Conemaugh Township Area School District Board Policy 209.
3. As per Board Policy 235, the School Board reserves the right to approve **surveys** prior to their administration to students. All surveys and instruments used to collect information from students shall relate to the district's educational objectives. Parents shall have the right to inspect, upon request, a survey created by a third party prior to administration or distribution to a student. Such requests shall be in writing and submitted to the building principal. Parents have the right to have their child opt out of a survey, with submission of a letter to the building principal.
4. The Conemaugh Township Area School District does have a **Limited English Proficiency Program** in place (k – 12). Student's placement, program, policy, and parent involvement are detailed in Board Policy 138. This policy is available from the building principal.
5. The Conemaugh Township Area School District has a **Migrant Education Program** in place for students in kindergarten through grade 12. Student's placement, program, policy, and parent involvement are detailed in Board Policy 142. This policy is available from the building principal.
6. The Conemaugh Township Area School District has a **Homeless Education Program** in place for students in kindergarten through grade 12. Student's placement, program, policy, and parent involvement are detailed in Board Policy 251. This policy is available from the building principal.
7. The Conemaugh Township Area School District has a **Home Language Survey** in place for students in kindergarten through grade 12. Student's placement, program, policy, and parent involvement are detailed in Board Policy 200. This policy is available from the building principal.
8. The Conemaugh Township Area School District has a **Persistently Dangerous School Program** in place for students in kindergarten through grade 12. Student's placement, program, policy, and parent involvement are detailed in Board Policies 143 and 144. These policies are available from the building principal.
9. The Conemaugh Township Area School District has a **Federal Programs Complaint Process** in place for students in kindergarten through grade 12. Student's placement, program, policy, and parent involvement are detailed in Board Policies 103 and 906. These policies are available from the building principal.
10. The Conemaugh Township Area School District notifies parents annually of our school's yearly **SPP Score (Student Performance Profile)** for their child's district and school. This is included in the fall newsletter. District and Annual report Cards will be distributed each fall when the PSSA results are available from the state. These will be in the building offices and on the District website as detailed in Board Policy 919.
11. The Conemaugh Township Area School District has a **Parent Involvement Policy** that contains all components required by Title I. This document is in accordance with Board Policy 917 and is reviewed and revised annually.
12. The Conemaugh Township Area School District has a **Title I** program in place. Components of the program are:

Title I

Title I is the largest federal assistance program for our nation's schools. Conemaugh Township Elementary School operates a School-wide Title I program. The purpose of a Schoolwide Title I program is to assist schools in providing a quality educational experience that enables all learners to meet state standards. Schoolwide Title I funds are used to increase the quality of learning time and to provide an enriched curriculum for all children in order to achieve the program goals. Schools are required to include parental/guardian input in planning and implementing the Title I program as this type of communication and collaboration is critical

to student success.

Conemaugh Township School District
District Title I Parent and Family Engagement Policy
(reviewed May 2022)

The Conemaugh Township School District is committed to the belief that all children can learn and acknowledges that parents share the school's commitment to the educational success of their children.

The Conemaugh Township School District believes that the education of students is a joint responsibility that is shared by the parents/guardians. To ensure that the best interests of each student are served in the education process, a strong program of communication and cooperation between home and school must be maintained and parental involvement encouraged.

The Conemaugh Township School District feels that it is the parents/guardians who have the ultimate responsibility for their children's behavior in school, including the behavior of students who have reached the legal age of majority but are, for all practical purposes, under parental authority.

To this end, a written plan for Title I Parent Involvement that establishes programs and practices to enhance parent involvement and reflects the needs of students and families will be jointly developed by parents and school staff. The plan will provide a sense of direction for designing initial and ongoing activities.

The plan will also include a school-parent compact and support the development, implementation and regular evaluation of parent involvement program by parents. Implementation of the plan will be a priority of the school community.

1. The LEA, in consultation with parents, shall develop written policies to ensure that parents are involved in the planning, design and implementation of the program. The LEA must make the policies available to parents of participating children.
2. The LEA shall provide parents, where practical, with reports on their children's progress, conduct parent conferences, and make education personnel accessible to parents.
3. Opportunities for regular meetings to offer parental input will be provided by means of scheduled parent conferences during the year and annual meetings held in the fall and spring of each year.
4. Information regarding the program will be shared with parents by means of our district website, hand-outs, parent workshops, and the annual meetings.
5. Parents will be informed of parental involvement requirements and other relevant provisions by the annual meetings held in the fall and the spring of each year.
6. The LEA shall provide reasonable support for parental involvement activities as parents may request (tutoring support, etc.).
7. The district, where possible, will provide information about programs, and activities in the language and form that parents can understand by means of explanations at meetings and parent mailings when needed.
8. The district will ensure that non-English speaking parents will be provided information on Title I and the progress of their children in a language or format they can understand.
9. Title I parent involvement activities will be coordinated with programs such as Head Start and other outside agencies.

Assessment of Parent Involvement: The LEA shall annually assess through consultation with parents, the effectiveness of the parental involvement program and determines what action needs to be taken, if any, to increase parental participation. Actions will be implemented for school improvement. The district will assess in the following manner: input of parents will be solicited at parent conferences and the annual meeting.

Conemaugh Township Elementary School
Title I Parent and Family Engagement Policy
(reviewed May 2022)

The Conemaugh Township I Elementary School believes that the education of children is a joint responsibility, one it shares with the parents of the school community. To ensure that the best interests of the child are served in this process, a strong program of communication between home and school must be maintained.

The Conemaugh Township Elementary School directs that the following activities be implemented to encourage parent-school cooperation:

- Parent-teacher conferences to permit two-way communication between home and school.
- “Meet the Teacher Night” to provide parents with the opportunity to see the school facilities, meet the faculty and sample the program on a first-hand basis. The Conemaugh Township Elementary School shall hold an open house at least annually.
- School-Parent Compact – Parents are given an opportunity to update the compact that is currently in place.
- Meetings of parents and staff members to explain and discuss matters of general interest with regard to child-school, child-home, or child-home-school relationships.
- Parents have access to Power Schools which will give them a daily update of their child’s academic progress, daily assignments, attendance, and current lunch balance.

For the benefit of children, the Conemaugh Township Elementary School believes that parents have a responsibility to encourage their child’s career in school by:

- Supporting the school in requiring that children observe all school rules and regulations, and by accepting responsibility for their children’s willful in-school behavior.
- Sending children to school with proper attention to their health, personal cleanliness and dress.
- Maintaining an active interest in the student’s daily work and making it possible for the student to complete assigned homework by providing suitable conditions for study.
- Reading all communications from the school, and signing and returning them promptly when required.
- Cooperating with the school in attending conferences to set up for the exchange of information on the child’s progress in school.
- Participating in school activities and special functions.

**Conemaugh Township Elementary
Title I Home/School Compact
(reviewed May 2022)**

School Pledge:

We will

1. Treat each child with dignity and respect.
2. Monitor student progress and update parents regularly.
3. Make sure all students get help as soon as it’s needed.
4. Explain our curriculum, expectations, and grading system to students and their families.
5. Continually work to improve teaching strategies so that we can successfully teach all children.
6. Make sure students understand their assignments and what they’ll learn from them.

Family Pledge:

We will

1. Let the teacher know if our child has problems with learning.
2. Monitor assignments, and encourage homework completion.
3. Encourage positive attitudes about school.
4. Participate in decisions relating to the education of our child.

5. Make sure our child attends school regularly.

Student Pledge:

I will

1. Believe that I can and will learn.
2. Let my teacher and my family know if I need help.
3. Pay attention, participate, and ask questions in class.
4. Do my homework, and turn it in when it's due.
5. Be respectful to everyone.

Title I Complaint or Concern Procedure

Parents/guardians who have a complaint or concern about the Title I services their child is receiving should observe the following procedure:

- 1) Contact the person that you have a complaint about to discuss both sides of the story.
- 2) If the problem remains, contact the building principal.
- 3) If it is still unresolved, contact the superintendent.
- 4) Finally, if unresolved, ask the superintendent to place the complaint on the following month's Board of Education agenda for further discussion.

Notice of Homeless Education Program

The federal "Every Student Succeeds Act" (ESSA) includes a provision to make sure that homelessness does not cause children to be left behind in school. Homeless children should have access to the education and other services that they need to meet the same challenging state academic achievement standards to which all students are held.

The Conemaugh Township School District is required to provide activities for and services to, homeless children, including preschool-age homeless children and youths, enabling them to enroll in, attend, and succeed in school or preschool programs.

The law requires all school districts to inform parents or guardians of their rights under this provision of ESSA. Specifically, it states that, pending resolution of a dispute about school placement, a school district must immediately enroll a homeless student in the student's school of origin or other school selected on the basis of the child's best interest and provide a written explanation of the rights of appeal to the parent or guardian of the student.

If you have any questions or concerns regarding Title I, please contact Mr. Thomas Kakabar, Superintendent and Federal Programs Coordinator (814-479-7575 /thomas.kakabar@ctasd.org).

Pre-K To Kindergarten and Grade 5 to Grade 6 Transition Plan

The Conemaugh Township School District aims to provide a seamless transition between area preschools and our kindergarten program. In order to do that, we communicate with area preschools regarding our curriculum, state standards, and kindergarten readiness skills. At times, professional development activities are offered to preschools. In the spring of each year during kindergarten testing, preschool staff are encouraged to accompany their students to the testing and observe the process with the parents. In May of each year, a building tour is conducted so that area preschools may visit the building, meet the teachers, and participate in learning activities.

As elementary students prepare to end their fifth grade year, a transition plan is in place to assist them with this process. In May

of each year, fifth grade students visit the middle school for a tour. During the tour, they are paired with a six grade mentor, learn how to open lockers, navigate the building, and enjoy lunch, games and activities. The middle school is open to students so that they may visit and tour over the summer months to ease anxiety that may set in. In August, an orientation is held for sixth graders, new students, and their families. This gives them an opportunity to view their schedules, walk through a typical day, and meet their teachers. Elementary and middle school staff and administration also meet to discuss students and their needs before the new year starts so that accommodations can be made to meet their needs. Teacher websites also contain helpful information for parents and contact information so that open lines of communication may be established.

Parent Right-to-Know Information

Parent Right to Know Information as Required by The Elementary and Secondary Education Assistance (ESEA) [Section 1112(e)(1)(A)] and the Every Student Succeeds Act [Section 1112(e)(1)(A)]

Your child attends the Conemaugh Township Elementary School, which receives Federal Title I funds to assist students in meeting state achievement standards. Throughout the school year, we will be providing you with important information about this law and your child's education. This letter lets you know about your right to request information about the qualifications of the classroom staff working with your child.

At Conemaugh Township Elementary School, we are very proud of our teachers and feel they are ready for the coming school year and are prepared to give your child a high-quality education. As a Title I school, we must meet federal regulations related to teacher qualifications as defined in ESEA. These regulations allow you to learn more about your child's teachers' training and credentials. We are happy to provide this information to you. At any time, you may ask:

- Whether the teacher met state qualifications and certification requirements for the grade level and subject he/she is teaching,
- Whether the teacher received an emergency or conditional certificate through which state qualifications were waived, and
- What undergraduate or graduate degrees the teacher holds, including graduate certificates and additional degrees, and major(s) or area(s) of concentration.

You may also ask whether your child receives help from a paraprofessional. If your child receives this assistance, we can provide you with information about the paraprofessional's qualifications.

The Every Student Succeeds Act (ESSA) which was signed into law in December 2015 and reauthorizes the Elementary and Secondary Education Act of 1956 (ESEA) includes additional right to know requests. At any time, parents and family members can request:

- Information on policies regarding student participation in assessments and procedures for opting out, and
- Information on required assessments that include
 - subject matter tested,
 - purpose of the test,
 - source of the requirement (if applicable),
 - amount of time it takes students to complete the test, and
 - time and format of disseminating results.

Annual Public Notice of Special Education Services and Programs 2021-2022

The Conemaugh Township Area School District provides a free, appropriate, public education to exceptional students according to state and federal law. To qualify as an exceptional student, the child must be of school age, must be in need of specially-designed instruction, and must meet eligibility criteria for mentally gifted and/or one or more of the following physical or mental disabilities,

as set forth in Pennsylvania State Standards: autism/pervasive developmental disorder, blindness/visual impairment, deafness/hearing impairment, mental retardation, multi-handicap, neurological impairment, other health impairment, physical disability, serious emotional disturbance, specific learning disability, speech/language impairment.

The District engages in identification procedures to ensure that all students receive an appropriate educational program, consisting of special education and related services which are individualized to meet the educational needs of the student, and reasonably calculated to yield meaningful educational benefit and student progress, at no cost to the parents and in compliance with state and federal law.

For additional information, please see school board policy 113 and the full Annual Public Notice on the district website:

<https://www.boarddocs.com/pa/cnmt/Board.nsf/Public?open&id=policies#>

<http://www.ctasd.org/Student-Services>

**The numbers following subject headings reference District Board Policies. Copies of District policies are available upon request in the school office.

ACADEMIC/ CONDUCT EVALUATION (213)

The following grading system has been adopted as indicated:

Grades 1 – 5

A = 92% - 100% - Excellent work

B = 82% - 91% - Good work

C = 72% - 81% - Average work

D = 62% - 71% - Having difficulty

E = 0% - 61% - Failure

O = 92% - 100% - Outstanding

S = 72% - 91% - Satisfactory

N = 71% - 0% - Needs to Improve

P = Participation

Kindergarten and Grade 1

S = Secure; Student consistently performs and applies the skills consistently and independently

D = Developing; Student shows some understanding during independent practice but errors still occur

C = Concern; Student demonstrates limited understanding and cannot complete the task independently

NA/No mark = Skills not addressed this period

ADMISSION OF BEGINNERS (201)

A child is eligible for admission to kindergarten if she/he has attained the age of five (5) **before** the first day of September. A birth certificate as proof of age and birth date, documentation of compliance with the state mandated immunizations, and three forms of proof of residency must be provided to the school when registering for entrance to school. Unless there is a medical condition, all children must be potty trained before beginning school. Registration for incoming kindergarten students is generally held in the second semester. As of the 2020-2021 school year, compulsory school age shall mean no later than age six (6) until age eighteen (18).

ALTERNATE HOME/ALTERNATE BUS OR BUS STOP

You are encouraged to establish an alternate home for your child where they will be properly supervised in case you are not home when your child arrives.

Early dismissals, emergency dismissals, and working parents are specific cases where the alternate home will provide safety for your child and peace of mind for you, the parents. The alternate home should be a friend or nearby neighbor who will care for your child in case of an emergency. **REMEMBER TO UPDATE YOUR CHILD'S STUDENT EMERGENCY CARD BY NOTIFYING THE SCHOOL AS SOON AS CHANGES OCCUR.**

If a child is going home with another student, both parties are required to submit a note to the teacher that details the date, students' names, bus number, and bus stop.

ANIMALS / PETS

Animals and/or pets are not permitted to be brought to school without the permission of the classroom teacher and the principal. Proper care, feeding, and containment are required. NEVER bring an animal or insect to school in a glass container or on the school bus.

ATTENDANCE (204)

Students absent **for any reason** should return to school the next day it is in session with an excuse from either their parent/guardian or a physician. If the student does not turn in an excuse, he or she will be given a blank excuse form for parents to complete. **All excuses must be submitted to the school within three (3) school days or the absence will be considered unexcused/illegal.** An excuse must be provided to cover any/all dates a student is absent. A doctor's excuse is required if your child is absent due to a contagious condition or illness. **Excuses may be faxed to the school at (814)479-7497 or emailed to esattendance@ctasd.org.**

On occasion students need to be dismissed from school for health appointments or extenuating circumstances. We encourage the scheduling of appointments for times other than school hours. Parents are to notify the elementary office in writing of the dismissal time and report to the office to sign out their child. An excuse will be necessary for the absence. No student will be permitted to leave the building with anyone but the parent unless written notification is received by the office. This policy is for the protection of the students and those individuals involved.

If you know your child will be absent for any known prolonged period of time, please inform your child's teacher(s). Parents are encouraged not to take their children out of school for vacation. **Requests to remove children from school for educational trips must be submitted in writing to the building principal at least one week before the impending departure date. If the trip is educational in nature, up to three days of the absence may be considered excused.** If it is necessary to be away during the school year, please arrange with teachers to obtain school work *prior to the absence*. Students may be asked to complete a vacation journal describing the educational opportunities the child participated in. A student with more than 3 unexcused absences in a school year or a history of unexcused absences may be denied approval for an educational trip or participation in a field trip or in-school activities. See Appendix C for a copy of the legally excused absence form.

The District shall keep the parent/guardian informed as to their child's attendance via report cards, the parent portal of PowerSchool, and in some cases, attendance letters. In case of chronic irregular attendance, school authorities will request a physician's certification showing such absences to be justifiable. Parents may be notified by mail when their child has missed 5 and 10 days or more of school without a doctor's excuse. **A maximum of ten (10) days of cumulative lawful absences verified by parent notification may be permitted during a school year. All absences beyond ten (10) cumulative days verified with a parent excuse each year will require an excuse from a physician. Any days absent after ten (10), without a physician's excuse, will be considered unexcused and/or unlawful.** Exceptions may be made due to extenuating circumstances (e.g., extended hospitalization) and only after review by the building principal.

When a student's absence is a result of a medical or court appointment, the student must secure a medical/court appointment excuse from a physician, attorney, etc., at the time of the appointment. The excuse should be turned in to the main office upon return to school. **Every attempt should be made for students to return to school following medical/dental appointments.** In the case of a chronic illness or injury, a physician's excuse must be provided every 45 days.

According to Conemaugh Township Area School District policy, the following conditions constitute reasonable cause for absence from school:

1. Illness

2. Professional health care or therapy
3. Quarantine
4. Recovery from accident
5. Required court attendance
6. Death in immediate family
7. 4H/FFA project (with prior approval)
8. Religious holiday (with prior approval)
9. Non-school sponsored educational tours and trips (with prior approval)
10. College or postsecondary institution visits (with prior approval and documentation)
11. Family emergency
12. National Veterans' Organization Event (with prior approval)
13. Other urgent reasons such as homelessness or foster care

If you are uncertain as to whether a contemplated absence will be excused, you should discuss the circumstances of the possible absence with the school principal prior to the absence. When a student under seventeen (17) years of age accumulates his/her first day of unlawful absence, a notice will be served to the parent or guardian by mail. Upon the accumulation of a third unlawful absence, the student will be referred to the SAP team and a school attendance improvement plan will be developed. When a student reaches their fifth (5) illegal absence, a certified letter will be issued to the parents/guardians. **Upon accumulation of a sixth (6) day of illegal absence, a notice will be filed with the Magisterial District Judge for issuance of a summons and hearing.** Each additional unlawful absence will result in additional filings with the district justice.

If a student has more than 3 unexcused absences and more than 20 total absences in a school year, they may be:

- a. Provided alternative education
- b. Required to undertake a project or extra work
- c. Be retained

An appeal process has been established for parents/guardians or students who believe privileges have been denied unjustly due to attendance issues.

If students are absent from school, they will not be permitted to attend evening activities. This includes games, concerts, practices, etc.

BIRTHDAYS

Parents are welcome to provide a store-packaged snack for their child's class to celebrate his/her birthday. Parents should contact the teacher to confirm details for the date and type of snack permissible. Parents are discouraged from sending students balloons/flowers/gifts at the school for birthdays and other special occasions as it takes away from the instruction going on in the classroom.

BREAKFAST AND LUNCH PROGRAM (808)

All students are encouraged to participate in our FREE breakfast program. Students who are eating breakfast should report directly to the cafeteria upon arrival at school. **In order to participate in the breakfast program, students must arrive at school before 8:55 am.**

Elementary student lunches will cost \$2.55 (.40 cents for a reduced student). Students making purchases from the cafeteria may pay on their account on a daily basis **during homeroom period**. A computerized system is in place at the school, which allows students to place money in their cafeteria account from which all purchases will be deducted. "Extras" may be purchased on a daily basis and deducted from your child's account. The system enables the staff to print out a summary (**at the parent's request**) of purchases, payments, and the balance in the account. Checks should be made payable to the Conemaugh Township Area School District.

Parents can also deposit money into a child's account and check the balance by accessing the LunchTime portal. More information regarding that program is on the District website under the parent tab. If you have any questions, please feel free to contact our Food Service Director at 479-2328.

Students who are eligible for federally-subsidized free or reduced-priced meals may apply for this program. Applications will be sent home at the start of the school year and may also be obtained from the main office at anytime during the school year.

LUNCH CHARGES (808)

Charging lunch is permitted as a courtesy on an **EMERGENCY BASIS ONLY**. District policy permits a maximum charge of \$20.00 negative balance. Purchases for a la carte items and snacks will be permitted only if there is a positive cash balance on the account. Parents will be notified of outstanding charges. Payment for charged lunches should be made to the school cafeteria the day after the charge. A child's cafeteria balance may be accessed through the parent portal of the PowerSchool program on the CTASD website.

BUILDING AND CLASSROOMS (802)

The Elementary building accommodates students in grades K through 5. All correspondence to the Elementary School should be mailed to 1516 Tire Hill Road, Johnstown, PA 15905-7822. The telephone number at the Elementary School is 479-4080.

BUS RIDING (810)

The safety and care of children riding the bus is a major concern that demands a high degree of responsible behavior from each child along with parental cooperation. It is important that:

1. Your child wait at the assigned bus stop in an orderly manner for the bus to arrive.
2. Your child is properly dressed to wait for the bus. Please listen to the weather forecast.
3. Arrangements are made with other adults to monitor children while they are waiting for the bus.

As per School District Policy, requests for bus stop changes must be submitted in writing by October 1st of the school year. A copy of the entire policy is available upon request in the main office or may be accessed on the District website.

NOTE: In rare cases, students may be late arriving home from school as a result of extreme circumstances (e.g., bus problem). School officials will personally attempt to contact parents/guardians to apprise them of any such situation.

BUS RULES (810)

Please review the following rules with your child. While waiting for the bus:

1. Remain on the sidewalk. Do not go into the street or onto private property.
2. Wait for the bus to come to a complete stop before attempting to get on.
3. Do not push, shove, or hit others while boarding the bus.

While on the bus:

1. Go directly to your seat and stay seated.
2. Sit facing the front of the bus.
3. Keep arms and head inside bus.
4. Open windows only with the permission of the bus driver.
5. Sit quietly. Talk in a normal voice.
6. Wait until the bus comes to a complete stop before leaving your seat to depart the bus.
7. Leave the bus in an orderly manner. Keep hands and feet to yourself.
8. Obey and cooperate with the bus driver.
9. Students must keep the bus clean and free from litter at all times.
10. Students must not damage the bus in any manner.

****To help ensure the safety of all students, video cameras may record students while on the school bus.***

Riding the school bus is a privilege. This privilege may be suspended if a student chooses to violate the rules of safety and courtesy. Infractions will be reported to the principal and disciplined accordingly. Students may be suspended from the bus at the discretion of the principal. Parents are responsible for transporting students to and from school during all bus suspensions. Students not attending school during their bus suspension will be marked illegally absent, at which time the Attendance Policy outlined on page 12 will be followed. Any questions regarding bus schedules, bus stops, etc. should be directed to the Director of Transportation. **District buses are equipped with video cameras that record both video and audio.**

Tentative bus schedules will be posted to the district website in early August.

BUS SURVEILLANCE CAMERAS

Please be advised that the Conemaugh Township Area School District completed the installation of surveillance cameras inside each of the buses that transport students to and from school and for the majority of the athletic travel. The surveillance cameras will provide safety for our students and staff. Surveillance cameras can and will be utilized to aid in investigations of student misconduct that occur on the buses. Additionally, the sound recording mechanisms will be active as students travel on the buses.

BUS STOPS (810)

The information listed hereafter addresses bus stops, requests to change/add a bus stop, and safety issues as listed under the District's Transportation Policy #810. In part, the policy reads:

SCHOOL BUS STOPS: *The assignment of bus stops is the responsibility of the District. Parents must recognize that bus stop assignments cannot be customized to meet every individual need and still be part of an efficient and economical transportation system. Bus stop assignments shall be made in accordance with recognized State policies, school code, and the Commonwealth of Pennsylvania, Department of Transportation criteria for hazardous walking routes.*

Students in grades K-3 must be accompanied to and from the bus stop by a responsible adult. We will not be accepting phone calls or emails during the day to change a child's stop. Please send a note with your child in the morning if they are riding a different bus.

REQUESTS FOR NEW BUS STOPS (810)

1. Any request for new bus stops will be evaluated from a traffic safety viewpoint only, using criteria listed under Pennsylvania Department of Transportation criteria for determination of hazardous routes.
2. The District cannot consider factors that are associated with individual families or parental situations. Such concerns are expected to be resolved by the family or parent, not the district. Examples:
 1. Parents not being able to see child walking to bus stop and/or waiting at bus stop
 2. Neighborhood feuds or conflicts with nearby residents
 3. Change in parent's work schedule or babysitting arrangements
 4. Parent not able to walk to bus stop with the child because of other obligations
 5. Unrestrained pets in neighborhood
 6. Dual or multiple guardianship
3. All requests for a bus stop change must be made prior to October 1st. Requests for a bus stop change will be reviewed by the Superintendent and/or designee. **The Director of Transportation will personally inspect all proposed new bus stops prior to making a decision.** The family cannot anticipate an answer before forty-eight (48) hours.

EMERGENCY SITUATIONS

1. A child may be permitted an alternate bus stop in the event of a non-recurring emergency (i.e., family illness, death, etc.)
2. All kindergarten through grade 12 students will be discharged at their assigned stop.
3. It is the responsibility of the parent/guardian to provide appropriate supervision for their child at the bus stop.
4. Any students not discharged at their assigned bus stop will be returned to the Elementary School.
5. A district employee will remain at the Elementary School each afternoon until the last bus radios in to the dispatcher that all students have been discharged from the bus.

CAFETERIA BEHAVIOR

In order for all to have an enjoyable breakfast and lunch, the following rules should be observed:

1. Students are to wait in line politely. Students violating this rule will be sent to the back of the line.
2. Speak in a quiet, courteous manner.
3. Students are to display proper eating manners.
4. Students are to obey the adults in charge of cafeteria/recess duty.
5. Students are not to run in the cafeteria.
6. Throwing food WILL NOT be tolerated. Students are expected to keep tables and floor clean of paper and food.
7. Students are not permitted to share items from their lunches.
8. Students are not permitted to bring soda or energy drinks in their lunches.

CRIMINAL ACTS ON SCHOOL PROPERTY (218)

In instances of criminal acts on school property, the adopted school board policy will be followed.

DISCIPLINARY MEASURES

If a child's behavior is not consistent with the expectations established by the student and school authorities, corrective measures will be taken accordingly. Most disciplinary infractions will be handled by your child's teacher, however all infractions will be handled in accordance with the Conemaugh Township Area School District's Student Discipline Code. Copies of the district's discipline code may be found in Appendix A at the end of this handbook.

DRESS CODE (221)

The Board recognizes that each student's mode of dress and grooming is a manifestation of personal style and individual preference. The Board will not interfere with the right of students and their parents to make decisions regarding their appearance, except when their choices affect the educational program of the schools or the health and safety of others. The building principal shall be responsible to monitor student dress and grooming in his/her building.

An individual's dress, personal appearance, and cleanliness should reflect a sensitivity and respect for others. The fact that the school allows a wide variety of school clothes does not necessarily mean we feel all styles are equally appropriate. Students should dress and groom themselves so as to meet fair standards of safety and health and so as not to cause disruption to the educational process:

- Wearing apparel which tends to create a disturbance in the academic atmosphere is not permitted. The length of shorts, skirts, and dresses must be to the student's fingertips.
- Ribbed or spaghetti strap (two finger width) tank tops, shirts exposing midriff, unbuttoned shirts except at the neckline, shirts containing suggestive or "double meaning" statements, or shirts advertising alcohol, drugs or tobacco, or extracurricular activity uniforms with short skirts, or clothes tending to overexpose are not permitted.

- Spandex clothing is NOT to be worn as outer clothing. Students who are in school with inappropriate attire will be placed in in-school suspension until appropriate attire is brought to them.
- For safety reasons, flip flops cannot be worn. Students are not permitted to wear shoes without a backstrap. Shoes with wheels are not permitted. Shoes with heels should be under 1 ½ inches in height and appropriate for the grade level.
- No hats or hoods, except on special days announced beforehand, are to be worn in school from morning homeroom until dismissal. This includes girls and boys.
- Coats are not to be worn to class unless directed by the teacher in charge. This would not include light denim jackets, vests or sweaters/sweatshirts, which may be worn.
- No chains are permitted in school. Metal “spiked” neck or wrist ware is prohibited. Safety pins or straight pins used on clothing or book bags are prohibited.
- Body piercing (other than ears) is prohibited in grades K-5.
- Tattoos and inappropriate or excessive temporary body art is not permitted.
- Students are discouraged from applying hair color to their hair or from wearing distracting hair styles unless it is for a themed day or special event as approved by building administration.

DRUG, ALCOHOL, AND TOBACCO USE POLICY (222)

The Conemaugh Township Area School District is dedicated to providing a healthy, comfortable, and productive environment for faculty, staff, students, and citizens. The Conemaugh Township Supervisors, in cooperation with the Conemaugh Township Area School District, has adopted *Ordinance No. 602* on September 14, 1995. This ordinance prohibits the possession and/or use of drugs, alcohol, and tobacco in certain public places or places of public assemblage located within Conemaugh Township, requiring enforcement by persons having control of premises; prescribing penalties for violation of its provisions. Any person who violates this ordinance shall be guilty of a summary offense, and upon conviction, shall be sentenced to pay the costs, plus a fine of up to ONE HUNDRED DOLLARS for the first offense; up to ONE HUNDRED FIFTY DOLLARS for a second offense; and at least ONE HUNDRED FIFTY DOLLARS but not more than FIVE HUNDRED DOLLARS for a third or subsequent offense. Upon failure to pay costs and fines as imposed, a person shall be subject to incarceration for a period of no less than SIXTY (60) days.

ELEMENTARY INSTRUMENTAL MUSIC PROGRAM

The elementary instrumental music program is an elective course available to all students in fourth and fifth grades. In this program, every child will be encouraged to develop his aesthetic potential, as well as his musical intellect, to its highest possible level. Playing a musical instrument offers your child an opportunity for self-expression and creativity through their active participation in the music program. The student will also develop a keener sensitivity to the elements of music and will become an educated music listener as well as a music performer.

During the first semester of fourth grade, all students will participate in the pre-band recorder program. The purpose of this program is to provide students with an introduction to the study of instrumental music. This program also creates the desire to play an instrument while enhancing a sense of appreciation for music. Students will receive one group lesson per week and will perform in a concert.

Following the successful completion of the recorder program, students expressing an interest in continuing with a band instrument may try out. Tryouts will be conducted by the music instructor in the band room. Results of this procedure will be sent home to the parents. The instructor will recommend that the parents rent an instrument from the music dealer of their choice for a period of three or four months. Students will receive one group lesson per week starting the second semester.

Each student in fifth grade will receive one small group lesson per week. One band rehearsal a week will also be scheduled. Efforts will be made in scheduling lessons to keep class time interruption to a minimum. All lessons and rehearsals are held

during the regular school day. Students will perform during various programs throughout the year.

Students are encouraged to begin their lessons as soon as the instruments are available. Students leaving class for lessons are reminded that they are responsible for obtaining assignments and making up missed work. To ensure a successful program, students will be permitted to drop the instrumental program from their schedules **only during the first two (2) weeks of each semester. Parents must formally make this request in writing and direct it to both the teacher and the principal.**

ELEMENTARY VOCAL MUSIC PROGRAM

The elementary vocal music program is a course that all students in grades K-5 participate in on a weekly basis. In this program, every child will be encouraged to perceive the elements of music, perform music, read music and demonstrate an effective response to music. These goals are achieved through singing, listening, moving to music, playing rhythm and melodic instruments, and reading music.

Participation in class and at our concerts is paramount. A team cannot perform at its best if some of the members are absent. Attendance at the concert is an expectation and is part of each child's grade. All concerts are announced months in advance to allow families time to schedule other events around them. If your child is unable to attend a concert, please notify Mrs. Dull directly.

END- OF- DAY PICK-UP

Students who will be picked up at the end of the school day and will **not** riding the bus home **MUST BRING A NOTE** stating such. The note should state who will be picking up the student, as well as the days the pick-up will be in effect. A note at the beginning of the school year will suffice for students who will be picked up at the end of every school day.

Students being picked up at the end of the day will be called to the gym or other designated area at approximately 3:25. Parents, or those picking up a student, must park in the parking areas **AT THE FRONT OF THE BUILDING near the gymnasium**. An adult must come into the building to accompany the child outdoors. Anyone signing out a student **may** be required to show proof of identification in the form of photo identification.

Parents picking up students at the end of the school day are asked not to arrive before 3:25. The gymnasium doors will be opened by a staff member at 3:25 for parent entry.

FIELD TRIPS (121)

Students in grades K-5 may participate in field trips outside of the school building during the school year. They are required to follow the same rules they do while in school. Chaperones are assigned to each homeroom to maintain safety and assist the teachers while on the field trip. One chaperone is required for every ten students (K-5) as per board policy. The appointment is the responsibility of the building principal and the PTA. If parents are interested in serving as a chaperone, they are encouraged to join our PTA and become an active member.

FIREARMS / WEAPONS POLICY (218.1)

Students are not permitted to possess (including book bags, back packs, gym bags, purses, etc.), handle, and/or transmit weapons on school grounds, at school-sponsored activities, or on buses and other vehicles provided by the school district, under any circumstances.

As used in this policy, "weapon" means a gun of any type, operable or inoperable, facsimile (look alike) of a gun, firearm, shotgun, rifle, nunchaku, blackjack, sandbag, tazers, shockers, pipe, club, brass knuckles, dagger, knife, razor, cutting instrument, (the blade of which is exposed in an automatic way by switch, push button, spring mechanism, or otherwise), or any instrument or implement capable of the infliction of serious bodily injury. Mimicking the use of a gun, knife or other type of weapon on school property is discouraged as well.

An individual "possesses" a weapon in violation of this policy when the weapon is found on them. Additionally, an individual will be deemed to be in possession of a weapon if the weapon is found in his/her personal property (e.g., book bag, gym bag, purse, back pack, etc.).

Students in possession of a weapon, or any other device that could cause harm to another student, will be administered to in the following manner:

1. Ten days suspension (out of school)
2. Notification of proper authorities
3. Formal hearing before the School Board. If the student has been found in violation of the weapon policy, they shall be expelled for a period of not less than one year.
4. Students found in violation of the weapons policy shall be denied access to the schools and school-related property in addition to being denied the opportunity to participate in co-curricular and extracurricular student activities.

If a weapon is to be brought to school for an APPROVED school or school-related activity, the student's parent/guardian must bring the weapon to the school office to be left with an administrator. The parent/guardian must return at the end of the day to retrieve the weapon from the office.

District policy regarding weapons is available upon request in the school office.

FUNDRAISING

Fundraising is prohibited during school hours.

GENERAL BEHAVIOR (218)

Parents can expect their children to be treated as individuals who have important feelings. Children will be treated in a warm, yet firm and fair manner consistent with common sense, and decency, while utilizing behavioral control methods. Our goal is to assist the development of self-control within each child. Self-control is a learned skill which needs to be practiced throughout the school day. It is difficult for students to learn and understand concepts being explained by the teacher without self-control. Preventive and corrective measures for misbehavior will be initiated to support a proper learning environment.

Both parents and students should know what is expected in regard to proper conduct in school. Listed below are some of the responsibilities of students. Please review them with your child.

1. Attend school regularly and punctually
2. Respect those in authority at all times
3. Conduct yourself in the classroom so as not to disturb the learning atmosphere
4. Treat others in a courteous and respectful manner
5. Speak quietly while walking through the halls
6. Leave the room only with permission
7. Tampering with fire alarms is against the law
8. Lavatories and hallways should be kept clean and free of graffiti
9. Use good manners in the cafeteria
10. Complete academic assignments in a timely manner

GUIDELINES FOR SCHOOL DISCIPLINE OF EXCEPTIONAL STUDENTS (218, 233)

The district recognizes that the basic principles underlying this discipline policy reflect the basic rights of handicapped students mandated by *Federal Law 94-142, Pennsylvania Special Education Regulations (Chapter 14) and Standards (Chapter 342)*, and court decisions: (1) no handicapped students may be deprived of a free appropriate public education as the result of misconduct; (2) changes in a handicapped student's placement may be effected only through the procedural mechanisms of 94-142 and State Board Regulations.

These principles do not prohibit handicapped students from all discipline, nor are handicapped students entitled to participate in

programs when their behavior impairs the education of other students.

School officials, as defined and authorized by the Board, may employ reasonable disciplinary measures that neither cause deprivation of an appropriate public education nor are substantial enough to constitute change in placements. Temporary placement in isolated study cartels, timeouts, detention, or the restriction of privileges and/or extracurricular activities may be utilized. School officials may request a change in the placement of exceptional students who have demonstrated that the present placement is inappropriate by disrupting the education of other students.

HEARINGS (233)

Education is a statutory right. Students must be afforded all appropriate elements of due process if they are to be excluded from school. In a case involving a possible expulsion, the student is entitled to a formal hearing which is a fundamental element of due process and is required in all expulsion actions. This hearing may be held before the board of school directors or a duly authorized committee of the board. When the hearing is conducted by a committee of the board, a majority vote of the entire school board is required to expel a student.

HOMEWORK (130)

Homework is assigned at the discretion of the classroom teacher. Homework shall be understood as any assignment to be completed outside regular school hours. The following objectives exist with regard to homework:

- Homework reinforces learning developed in the classroom.
- Homework allows students to complete work that has been started in the classroom.
- Homework strengthens individual weaknesses that a student might have.
- Homework helps students work independently and practice good study habits.
- Homework develops creativity, originality, and responsibility in a student.

If a student is spending an unreasonable amount of time on homework, it usually means that something is wrong. A student may not be using his independent work periods productively or may not understand the assignment. It might also mean that the time he/she is spending doing homework is not productive or that he has over-extended his schedule by participating in too many extracurricular activities. **In any event, parents are urged to contact the student's teacher whenever a concern about homework arises.** Parents are encouraged to be consistent in establishing a set time and place for their children to complete home assignments. Also, parents should monitor their children and be available to give assistance where necessary.

Each elementary student in grades two through five is issued a black & red Indian folder and an agenda book for the purpose of recording all daily and long-term homework assignments in addition to periodic parent/teacher communication comments. Parents are encouraged to review the agenda book daily.

HONOR ROLL / PRINCIPAL'S IMPROVEMENT CLUB (P.I.C.)

The Elementary School will recognize students who earn all A's, B's, O's and S's on their report card for scholarship and conduct at the end of each marking period in grades 2-5. Student conduct is an integral part of their evaluation. Continued occurrences may result in a grade of an N in the area of conduct on his/her report card. Receiving an N will affect honor roll status.

To qualify for the All A Honor Roll, students must earn:

- All A's and O's in the core content areas as applicable (Language Arts, Math, Science, Social Studies, Social Living and Spelling)
- All O's and S's in the special area courses (physical education, music, art, library, and computers) **and** overall conduct

To qualify for the A/B Honor Roll, students must earn:

- All A's, B's, O's, and S's in the core content areas as applicable (Language Arts, Math, Science, Social Studies, Social Living and Spelling)

- All O's and S's in the special area courses (physical education, music, art, library and computers) **and** overall conduct

Students that attain the All A Honor Roll or the A/B Honor Roll for the entire year will receive special recognition.

Students in grades 2-5 who meet the following criteria at the end of either the second, third, or fourth marking period are eligible to receive the P.I.C. Award:

- ◆ Student is not eligible for the standard Honor Roll
- ◆ Student must improve one full letter grade in any subject area
- ◆ Student must not decline a full letter grade in any subject area

INSTRUCTIONAL SUPPORT

Current education regulations now give the opportunity for any elementary student who experiences behavioral or academic difficulty the access to instructional support. At the core of the I.S.T. process is the belief that **"ALL STUDENTS CAN LEARN, AND ALL STUDENTS MATTER."** An instructional support team will work with the students, offering help and assistance in areas where they are experiencing academic, attendance or behavioral difficulties. This team will consist of the principal, guidance counselor, classroom teachers, and other specialists. The team will plan strategies so that the students receive an effective educational program that meets their individual needs. This program is available to all students in regular education classes. The goal is to keep the students in regular classrooms by giving the assistance needed for them to succeed. **Parents as well as teachers, are able to request this assistance for their child by contacting either the principal or guidance counselor.** Parents are also urged, and are welcome to work with and become part of, the support team.

INTERNET / TECHNOLOGY RESOURCES (815)

The purpose of the **Internet and E-mail** is to support research and education. Appropriate usage is defined as technology and/or Internet resources that are directly related to the curriculum/instruction. Even though the school district makes a "best" effort to filter/block/detect access to non-educational websites and monitor Internet traffic, student usage of these websites at any time would be classified as "inappropriate usage" of the technology and/or internet resource. The building administrator shall have the FINAL authority to determine what inappropriate use is. Students will be educated on proper computer/internet use at the beginning of and throughout each school year. They will be expected to use computer hardware appropriately as well. Students will sign an Acceptable Use Policy at the beginning of each school year. The AUP is located in Appendix B at the back of this handbook for parent review.

Students and staff are expected to act in a responsible, ethical and legal manner in accordance with district policy, accepted rules of network etiquette, and federal and state law. District policy regarding acceptable use of technology is available upon request in the school office.

LIBRARY USE

Students are permitted to check books out of the library on a weekly basis during their scheduled library class. Students in kindergarten and 1st grade may borrow one book at a time. Students in grades 2-5 may borrow two books at a time. However, if classroom assignments require additional books, students will be permitted to borrow those books also. Students are expected to have all books with them during their regularly scheduled library classes.

There is no fine for overdue books. There is a charge, however, for books that are lost or damaged beyond repair regardless whether the damage was accidental or intentional. Students are responsible for books in their possession. Charges for lost and damaged books are imposed according to current replacement cost of the book(s) in question.

If lost books are found after payment is made, money will be refunded. Checks should be made out to Conemaugh Township School District and may be held for a period of time. A receipt will be issued for money paid to the library for lost books.

MAKE-UP WORK

Students who have been legally absent from school will have the privilege of making up work. Students should make arrangements with teachers to make-up missed work. Students will be permitted to utilize the same number of days absent to make up classroom work. **Assignments not completed within the allotted time may result in the loss of points or a score of zero.**

Homework may be requested when a student is absent **two or more days**. **All requests for homework must be made before 11:00 a.m.** At the discretion of the teacher, certain work may require completion in school which may necessitate the loss of recess time.

In addition, students are reminded that they are responsible for making up all missed work. Obtaining assignments from their regularly scheduled class if they have been excused from class for any reason (i.e., doctor's appointment, band lesson, Release Time, etc.) is also the student's responsibility.

MENTALLY GIFTED PROCEDURES

Chapter 16 of the Pennsylvania Code presents the requirements for gifted education programming and services in public schools. The following includes the descriptions of the screening, evaluation, and identification process for students who are thought to be Mentally Gifted within Conemaugh Township Area School District.

Public Notice and Screening

Prior to screening, parents are informed of gifted education through the district website, student handbook, and school newsletters throughout the year. The screening process at Conemaugh Township Area School District includes multiple criteria. Sources of data include parent reports, teacher input, group ability and achievement scores, and results of rating scales. Second and fifth grade students will be administered a group ability test. After the scores have been received by the school district, the staff involved in screening will review the students' test scores to identify those students who scored 130 (standard score overall, verbal or non-verbal) or better regarding their cognitive abilities. Once those students are identified, the teachers will be contacted to provide additional information about a possible gifted referral. The Chuska rating scales will be completed by the student's teacher. Soon after, any student who would potentially be referred for a gifted evaluation will receive a screening using the SAGES (Screening Assessment for Gifted Elementary and Middle School Students) that will be administered either individually or in a small group. If the referral is supported through all of these measures and data collection, the student's parents will be contacted to determine if they support a referral for possible identification as gifted. If the parent is in support as well, the student will be recommended for a multidisciplinary gifted evaluation.

In addition to this formal screening that will take place during second and fifth grades, a student's parent or teacher may request a gifted evaluation at any time. The request shall be in writing. If the request is made orally by the parent to a teacher or other school staff in the District, the teacher will report this request to the guidance counselor, and permission to evaluate will be sent to the parent within ten calendar days of the oral request. There can only be one request made per school year. Once the permission to evaluate is received by the School District, the evaluation process will begin. The evaluation report will be presented to the parents no later than 60 calendar days (exemption for summer months) after the permission to evaluate is received by the District.

Evaluation and Identification

The school district will conduct the multidisciplinary gifted evaluation within 60 calendar days. The assessments will be conducted by the school psychologist. All information will be compiled into the Gifted Written Report. When considering results of assessments, the district will not make its determination of gifted ability based on IQ scores alone. Additionally, deficits in memory or processing speed, as indicated by testing, would not be the sole basis upon which a student would be determined not to be mentally gifted. In these cases, the GAI (General Ability Index) could be used to replace the full scale ability standard score. These decisions will be made by the school psychologist who interprets the scoring data. Additionally, students with IQ scores of lower than 130, when multiple criteria strongly indicate gifted ability, could be considered as gifted.

Following the completion of the GWR, the GIEP must be completed within 30 calendar days. The invitation to the GIEP meeting will be sent to the parents at least 10 calendar days prior to the scheduled GIEP meeting. The NORA (Notice of Recommended Assignment) can be presented to parents at the GIEP meeting or by certified mail within 5 calendar days after the completion of

the IEP meeting. The GIEP will be implemented within 10 school days after it is signed (or the start of the following school year if the GIEP is signed fewer than 30 days prior to the last day of school).

Gifted Programming

The Conemaugh Township Area School District provides gifted education opportunities that meet the needs of each individual student. The programming options are based upon the strengths and needs of each student identified as gifted. These options are agreed to by the GIEP team prior to implementation. Types of gifted programming offered to students at Conemaugh Township MAY include:

- Early entrance to kindergarten or grade/subject skipping
- Grouping based on instructional level
- Acceleration by level, grade, or subject or a compacted curriculum
- AP or honors courses available at expected or earlier than typical times
- Independent study
- Grouping with other gifted students for meaningful instruction with peers
- Enrichment in specific content areas as outlined in GIEP
- Learning contracts
- Other options as identified by the GIEP team

OLWEUS PROGRAM

Students attend weekly classroom meetings to reinforce the Olweus Anti-Bullying Program. Guidelines of the program include:

- We will not bully others
- We will try to help other students who are being bullied
- We will include students who are left out
- When we know someone is being bullied, we will tell an adult at school and an adult at home

OPEN-DOOR POLICY (908)

We urge parents to take an active interest in their child's education and encourage parent involvement at all times. Your involvement is a major element in our educational philosophy, accountability and success. There are many ways to become involved. We invite you to PTA meetings, school events and programs to explore the various ways you can make a positive impact on your child's education. If you have any questions, please feel free to contact school personnel.

Parents wishing to speak to a teacher are asked to call the school prior to the start of classes or at the end of the day. Conference appointments may be made by contacting your child's teacher.

PARENT-TEACHER COMMUNICATIONS (908)

Parent-teacher communication is a two-fold commitment requiring each to fully inform the other of the child's progress or problems. As parents, you may expect your child's teacher to contact you throughout the course of the school year. Communications may be made by notes, telephone calls, e-mails or conferences. Class instruction will not be interrupted for telephone calls. Parents are encouraged to monitor their child's progress by accessing the online parent portal located on the school's home page. Please contact the school office to receive information regarding online access to the parent portal.

We have scheduled **ONE (1) date, November 10, 2021, as Parent Conference Day.** If you have specific concerns about your child's progress, don't wait for the teacher to contact you, call the school. When parents and teachers work cooperatively, the child benefits.

OPENING EXERCISES / FLAG SALUTE (807)

A United States flag shall be displayed in classrooms and on or near each school building during school hours, inclement weather and at other times determined by the Board. District schools shall provide opening exercises that include a salute to the flag and/or recitation of the Pledge of Allegiance of the National Anthem. Students may decline to recite the Pledge of Allegiance or National Anthem and to salute the flag on the basis of personal belief or religious conviction. Students who choose to refrain from such participation shall respect the rights and interests of classmates who do participate. The Board may direct professional employees to conduct a brief period of silent prayer or meditation as part of daily opening exercises. Silent prayer or meditation shall not be conducted as a religious service or exercise.

PARTY INVITATIONS

Parents are asked to refrain from sending party invitations to school for distribution unless all homeroom students are included. This creates problems for uninvited students.

PERSONAL PROPERTY, MONEY AND VALUABLES

Parents are urged to write their child's name on hats, lunch boxes, sweaters, sneakers, and /or any other personal items. The *Lost and Found* is located in the main lobby. Items in the *Lost and Found* will be displayed to allow students adequate time to claim their property. Items unclaimed at the end of the semester will be donated to a nonprofit organization.

Students are reminded that only money required for the day should be brought to school and should be carried on the owner. Never leave money or valuables in your desk or coat pocket. Students are encouraged to let items of sentimental or monetary value at home, and should never be traded with other students. Arrangements can be made to bring certain items to school on a case-by-case basis with prior teacher approval. The school **will not** be responsible for lost or stolen items.

POWERSCHOOL

Parents can access their child's academic progress and attendance through the PowerSchool program on the CTASD website. Parents may sign up for this program in the school office.

PUBLIC ACCESS TO SCHOOL PROPERTY (707.1)

The Conemaugh Township Area School District recognizes and supports many legitimate activities that take place on school district property. The School District also recognizes a responsibility to ensure school property is treated with respect and used in a safe and reasonable manner. With this in mind, the School District established Public Access to School Property Guidelines which may be obtained in the school office.

PUBLICATIONS

In addition to a monthly lunch menu and newsletter, periodic publications from the district and other community agencies containing important information for parents may be sent home with the students. **PLEASE encourage your child to bring this information home.** Information may also be obtained by visiting the District website (www.ctasd.org). If you DO NOT wish your child's name or picture to be published, please complete and return the media release form that is distributed at the beginning of the school year. The media release form is to be utilized in its original manner. Alterations will not be accepted.

RECESS

Recess is time that may be allocated for students to take a break from their studies. Recess is a privilege which may be denied if a student has misbehaved or has not completed required school or homework assignments. Supervised recess will be outside, weather permitting (33 degrees or higher). Please keep in mind that your child will be sent outside in the outwear they arrive to

school in.

REGISTRATION (200)

Parents will be asked to complete the appropriate forms at the time their children are enrolled. During this time, a state birth certificate, immunization record, and three forms of proof of residency must be presented. It is vital that all information be accurate and up-to-date. School personnel need to know the telephone numbers of individuals to call in case of emergency.

IT IS IMPERATIVE THAT YOU NOTIFY THE SCHOOL AS SOON AS THERE IS A CHANGE OF ADDRESS OR TELEPHONE NUMBER.

All information received will be kept in the student's file and will only be used by school personnel for school-related business.

REPORT CARDS (212)

Report cards will be issued four times a year, in accordance with specific dates that are listed on the school calendar. Report cards include evaluations of the student's performance in academic areas, as well as overall conduct. Conduct grades will be reported as either an S or N.

REQUESTS TO BE EXCUSED

Parents are urged to schedule medical and dental appointments after school hours whenever possible. If your child has an appointment which requires an early dismissal, a note to the teacher **IN ADVANCE IS REQUIRED**. Unexpected early dismissals create classroom disruptions and impede the educational process.

ALL dismissals for appointments are made from the office, **NOT** from the classroom. Students will be dismissed **ONLY** to a parent or other properly **authorized and identified adult** who is required to sign the student out in the main office.

PLEASE REFRAIN FROM SCHEDULING FAMILY VACATIONS DURING THE SCHOOL YEAR. If such scheduling is unavoidable, requests for student excusals must be submitted in writing to the building principal at least one week *prior* to the vacation. Requests should include justification of the trip through the educational value to the student. It will be the student's responsibility to gather and complete classroom work from his/her teachers. Students may be required to submit a vacation journal / essay upon return. Please see the attendance section of this handbook for additional information.

RESPONSIBILITIES OF STUDENTS (218)

1. Students should assume responsibility for understanding rules and regulations established by their classroom teacher/teachers.
2. Students should express their opinions and ideas in a respectful manner so as not to offend or slander others. Vulgarity will not be tolerated.
3. Students are to assume full responsibility for completing all assignments on time.
4. Students must make arrangements for making up work missed due to an absence from school. Assignments not completed within the allotted time may result in a loss of points or a score of a zero.
5. Cheating will not be tolerated. Any student caught cheating will receive a zero on that assignment or test.
6. Vandalism and destruction of school property will be dealt with in accordance with state and local laws.
7. Students should assist the school staff in operating a school which is safe for all students. Fighting, running in the halls, pushing, and/or any action which may endanger another person is not permitted.
8. Students should dress and groom themselves to meet fair standards of safety and health, and not cause substantial

disruption.

9. **RADIOS, RECORDING DEVICES, MP3 PLAYERS, CAMERAS, ELECTRONIC DEVICES, TOYS, TRADING CARDS (including Pokemon Cards), COLOGNE, AEROSOL SPRAYS, AND COMPUTER GAMES ARE NOT PERMITTED IN SCHOOL.** Such items will be confiscated and returned only to the child's parent or guardian.
10. Students are asked to refrain from bringing crayons, markers, etc. to school without teacher approval.
11. Students must bring written parental consent for any of the following:
 - a. The student is not to go outdoors for recess and/or participate in physical education classes (doctor's excuse req.)
 - b. The student is to refrain from eating;
 - c. To accompany another student home after school, **both students MUST** have a note to that effect signed by the parent. Students should submit such requests to their homeroom teacher at the beginning of the day. Students **WILL NOT** be permitted to ride a different bus or go home with another student without proper parental authorization.
12. The USE of cell phones is not permitted. Students may keep a cell phone in their bookbag however, the phone must be turned off while at school and on the school bus.

RESPONSIBILITIES OF PARENTS (218)

Parents and teachers should understand that quite often school problems and home problems are interrelated. Consequently, direct communication between the school and the parents is always welcome and encouraged. Specifically, parents may help their child's education by assuming responsibility for the following:

1. Encourage your child to be well groomed.
2. Provide a quiet environment for your child to read and/or study.
3. Discuss school events with your family. Parental concern and encouragement foster success.
4. Support the school in its efforts to help all students.
5. Contact the teacher if any problems occur. Try to solve any problems which may arise with the school rather than with the neighborhood. Positive feelings at home will encourage your child to have positive feelings about school.
6. Volunteer your talents and efforts to help the school. We can always utilize parental help.
- 7. Please check with the homeroom teacher prior to sending in snacks or party items.**
8. Monitor your child's academic progress by checking folders and agendas nightly, utilizing the PowerSchool program on the CTASD website, and attending parent/teacher conferences when requested.
9. Ensure that your child is not absent/tardy in excess.

RETENTION POLICY

It is our policy that each student shall be moved forward in a continuous pattern of achievement and growth that corresponds with his/her own development and the system of grade levels and academic standards established for each grade. A student shall be promoted when he/she has successfully achieved the academic standards for the present level, based on the professional judgment of his/her teachers and the results of assessments. The District's goal is to assure that every effort will be made to remediate the student's difficulties before he/she is retained. The building principal will make the final decision.

SCHOOL CANCELLATIONS, DELAYED OPENINGS, OR EARLY DISMISSALS (805)

Inclement weather conditions may necessitate a delay in the start of school, a cancellation of school, or an early dismissal from school. Such reports are normally announced prior to 7:00 a.m. Parents are urged to listen to **local radio and television stations for updates/announcements**. If no announcement is made, school will convene as scheduled. **PLEASE DO NOT CALL THE SCHOOL**. When appropriate, the automated phone alert system will be activated to alert parents of delays/closings.

In the event of an unexpected early dismissal, please **DO NOT REQUEST CHILDREN STAY AT THE SCHOOL TO AWAIT YOUR ARRIVAL. UNLESS IN AN EXTREME EMERGENCY**, students will be sent on their regularly scheduled buses.

Please note that all school events are cancelled when inclement weather necessitates a school cancellation or early dismissal.

SCHOOL DAY (807)

Our school day begins at 9:00 a.m., dismissal begins at 3:25 p.m. The following is the bell schedule:

- 8:30 - Starting time for staff
- 8:30 - Student arrival / Breakfast program
- 9:00 - Tardy Bell
- 3:20 - Students prepare for dismissal
- 3:25 - Student dismissal
- 4:00 - Ending time for staff

Students who routinely ride to school with parents should be dropped off at the front entrance of the school. **STUDENTS SHOULD ARRIVE NO EARLIER THAN 8:30 A.M., AND NO LATER THAN 9:00 A.M.** Parents are asked not to park vehicles in front of the main entrance and leave the vehicle unattended. This is a safety issue and interferes with the loading and unloading of students. Parents should not arrive before 3:25 for end of the day pick-up. Gym doors will be opened by staff at 3:25 for parent entry.

SCHOOL SECURITY (907)

Since the safety of our children during school hours is one of our most important responsibilities, a security system has been implemented in our schools. Please assist us by respecting the security procedures as outlined.

All visitors must use the main entrance and follow the procedures below to be admitted into either building.

- Press the intercom button located at the main entrance and wait for a response from the office
- State your name and the reason for the visit
- Wait for the office to release the door (buzzing sound) before trying to open it

Pennsylvania State Law requires that **ALL** visitors report to the main office prior to classroom visit. Visitors are **NOT** permitted to go directly to the classroom. Visitors will be required to wear a visitor's badge. The badge will be issued after registering in the office and should be returned to the office upon completion of your school business. You may be asked to leave your keys in the office. They will be returned to you when you sign out and return the visitor's badge. Any items that need delivered to the classrooms (i.e., books, homework, treats, etc.) will be delivered from the office to the classroom in a timely manner.

SEXUAL HARASSMENT (248)

A copy of District policy regarding unlawful harassment is posted on the District website and available upon request in the school office.

SMOKING AND TOBACCO POLICY (222)

Smoking and use of tobacco products shall be prohibited in all school district buildings and on school properties. Smoking and/or tobacco use by students and/or personnel shall not be permitted within the school buildings, on school buses, or on school grounds which shall include parking lots and athletic fields, including the football stadium. This includes e-cigarettes and vape pens.

SNACKS

In accordance with the District's Wellness Policy, parents are asked to send in snacks that promote student health and help to reduce childhood obesity. Candy is **not** permitted to be sent to school as a snack or treat. **Drinks are limited to water.. All snacks should be store bought and include the original packaging.** Please check with your child's teacher before sending in a birthday snack. Refraining from sending in cookies and cupcakes is truly appreciated. **The general rule of thumb for snacks is 150 calories or less.**

SPECIAL EDUCATION REGULATIONS- CHAPTER 14

The Conemaugh Township Area School District abides by the regulations set forth in Chapter 14 of the special education regulations of the Commonwealth of Pennsylvania. The following is taken directly from the Pennsylvania Code (with the exception of adding in the local school district name) and refers to the procedures for evaluation, re-evaluation, the criteria for specific learning disabilities, and the development of a student's IEP. For additional information, one may refer to Chapter 14 of the Pennsylvania regulations or contact the special education coordinator at 814-479-4080.

Evaluation:

(a) The group of qualified professionals, which reviews the evaluation materials to determine whether the child is a child with a disability under 34 CFR 300.306 (relating to determination of eligibility), shall include a certified school psychologist when evaluating a child for autism, emotional disturbance, mental retardation, multiple disabilities, other health impairments, specific learning disability or traumatic brain injury.

(b) In addition to the requirements incorporated by reference in 34 CFR 300.301 (relating to initial evaluations), the initial evaluation shall be completed and a copy of the evaluation report presented to the parents no later than 60-calendar days after the agency receives written parental consent for evaluation, except that the calendar days from the day after the last day of the spring school term up to and including the day before the first day of the subsequent fall school term will not be counted.

(c) Parents may request an evaluation at any time, and the request must be in writing. Conemaugh Township Area School District will make the permission to evaluate form readily available for that purpose. If a request is made orally to any professional employee or administrator of the school entity, that individual shall provide a copy of the permission to evaluate form to the parents within ten (10) calendar days of the oral request.

(d) Copies of the evaluation report shall be disseminated to the parents at least ten (10) school days prior to the meeting of the IEP team, unless this requirement is waived by a parent in writing.

Re-evaluation:

(a) The group of qualified professionals, which reviews the evaluation materials to determine whether the child is a child with a disability under 34 CFR 300.303 (relating to re-evaluations), shall include a certified school psychologist when evaluating a child for autism, emotional disturbance, mental retardation, multiple disabilities, other health impairment, specific learning disability and traumatic brain injury.

(b) In addition to the requirements incorporated by reference in 34 CFR 300.303, the re-evaluation time line will be 60-calendar days, except that the calendar days from the day after the last day of the spring school term up to and including the day before the first day of the subsequent fall school term will not be counted.

(c) Students with disabilities who are identified as mentally retarded shall be re-evaluated at least once every two (2) years.

(d) Copies of the re-evaluation report shall be disseminated to the parents at least ten (10) school days prior to the meeting of the IEP team, unless this requirement is waived by a parent in writing.

Criteria for the determination of specific learning disabilities:

This section contains the State-level criteria for determining the existence of a specific learning disability. Each school district and intermediate unit shall develop procedures for the determination of specific learning disabilities that conform to criteria in this section. These procedures shall be included in the school district's and intermediate unit's special education plan in accordance with § 14.104(b) (relating to special education plans). To determine that a child has a specific learning disability, the school district or intermediate unit shall:

1. Address whether the child does not achieve adequately for the child's age or meet State-approved grade level standards in one or

more of the following areas, when provided with learning experiences and scientifically based instruction appropriate for the child's age or State-approved grade-level standards:

- (i) Oral expression
 - (ii) Listening comprehension
 - (iii) Written expression
 - (iv) Basic reading skills
 - (v) Reading fluency skills
 - (vi) Reading comprehension
 - (vii) Mathematics calculation
 - (viii) Mathematics problem solving
2. Use one of the following procedures:
- (i) A process based on the child's response to scientific, research-based intervention which includes documentation that:
 - (A) The student received high quality instruction in the general education setting.
 - (B) Research-based interventions were provided to the student.
 - (C) Student progress was regularly monitored.
 - (II) A process that examines whether a child exhibits a pattern of strengths and weaknesses, relative to intellectual ability as defined by a severe discrepancy between intellectual ability and achievement, or relative to age or grade.
3. Have determined that its findings under this section are not primarily the result of:
- (i) A visual, hearing, or orthopedic disability
 - (ii) Mental retardation
 - (iii) Emotional disturbance
 - (iv) Cultural factors
 - (v) Environmental or economic disadvantage
 - (vi) Limited English proficiency
4. Ensure that underachievement in a child suspected of having a specific learning disability is not due to lack of appropriate instruction in reading or mathematics by considering documentation that:
- (i) Prior to, or as a part of the referral process, the child was provided scientifically-based instruction in regular education settings, delivered by qualified personnel as indicated by observations of routine classroom instruction.
 - (ii) Repeated assessments of achievement were conducted at reasonable intervals, reflecting formal assessment of student progress during instruction, which was provided to the child's parents.

IEP

- (a) In addition to the requirements incorporated by reference (see 34 CFR 300.320-300.324), the IEP of each student with a disability must include:
- (1) A description of the type or types of support as defined in this paragraph that the student will receive, the determination of which may not be based on the categories of the child's disability alone. Students may receive more than one type of support as appropriate and as outlined in the IEP and in accordance with this chapter. Special education supports and services may be delivered in the regular classroom setting and other settings as determined by the IEP team. In determining the education placement, the IEP team must first consider the regular classroom with the provision of supplementary aids and services before considering the provision of services in other settings.
 - (i) Autistic support
 - (ii) Blind-visually impaired support
 - (iii) Deaf and hard of hearing support
 - (iv) Emotional support
 - (v) Learning support
 - (vi) Life skills support
 - (vii) Multiple disabilities support
 - (viii) Physical support
 - (ix) Speech and language support
 - (2) Supplementary aids and services in accordance with 34CFR 300.42 (relating to supplementary aides and services).
 - (3) A description of the type or types of support as defined in § 14.105 (relating to personnel).
 - (4) The location where the student attends school and whether this is the school the student would attend if the student did not have an IEP.
 - (5) For students who are 14 years of age or older, a transition plan that includes appropriate measurable postsecondary goals related to training, education, employment, and when appropriate, independent living skills.
 - (6) The IEP of each student shall be implemented as soon as possible, but no later than ten (10) school days after its completion.
 - (7) Every student receiving special education and related services provided for in an IEP developed prior to July 1, 2008 shall continue to receive the special education and related services under that IEP, subject to the terms, limitations, and conditions set forth by law.
- (b) In addition to the requirements incorporated by reference in 34 CFR 300.324 (relating to development, review, and revision of IEP), the Conemaugh Township Area School District shall designate persons responsible to coordinate transition activities.

Information on special education services and programs is available in the District office. Rights and due process procedures are safeguarded by state and federal laws and regulations. Additional information may be obtained from the District office by contacting:

Mrs. Jane Jugan
Conemaugh Township Area School District

STUDENT ACCIDENT INSURANCE (211)

Student accident insurance may be purchased for all students attending Conemaugh Township Area Schools. Insurance information will be sent home with each student during the first week of school. Parents interested in purchasing coverage for their child must complete the information promptly. Parents are under no obligation to purchase the insurance. Please note, however, that **only students with Student Accident Insurance will be covered if injured at school. The CTASD will not cover your child's injuries.**

STUDENT ASSISTANCE PROGRAM

The Student Assistance Program (SAP) is a program designed to work in partnership with parents to address concerns regarding a child's social and emotional needs that children in Kindergarten through fifth grade may encounter at school and/or home. Communication with parents/guardians, SAP team members, and the student, coupled with early intervention and an emphasis on the value of wellness, are the goals of our team. Various facets of support are offered to students and their families. Referrals to the SAP team may be handled through Mrs. Stroz or Mrs. Dull. Participation in the SAP program is voluntary.

STUDENT EMERGENCY/BUS CARD

A *Student Emergency/Bus Card* will be given to all students. It is **essential the card be completed in its entirety and returned to the school as quickly as possible** (preferably the next day). **IF YOU HAVE A CHANGE IN YOUR ADDRESS, TELEPHONE NUMBER, PLACE OF EMPLOYMENT, EMERGENCY PHONE NUMBER, OR YOUR CHILD'S HEALTH STATUS, PLEASE NOTIFY THE SCHOOL IMMEDIATELY.** This emergency information is necessary for school personnel to provide optimum protection for your children.

STUDENT GUESTS

Students are **not** permitted to bring other children to visit while classes are in session without prior permission from the building principal. Only properly enrolled students are permitted in the classroom during school hours.

STUDENT RECORDS (216)

Parents have the right to review their child's cumulative folder at any time. If you wish to review your child's records, please make an appointment by calling the school at 479-4080.

SUSPENSION OF STUDENTS (218, 233)

Students may be excluded from school for any of the following:

1. Possession of tobacco, alcohol, vape pens, e-cigarettes or any controlled substance on school property. Students found to be in possession of tobacco, alcohol, vape pens, e-cigarettes or any other controlled substance will have it confiscated and will be reported to the proper authorities.
2. Fighting
3. Insubordination
4. Profanity
5. Vandalism
6. Students will be required to make restitution if they accidentally break or damage school property while they are involved in prohibited activities.
7. Truancy (suspension will be in school)
8. Any other conduct detrimental to the welfare of any student, staff, or faculty member, or to the school in general.
9. Threats of violence

Prior to suspending a student, administrators will consult with the teacher who reported the infraction. Students will be interviewed by an administrator and/or counselor following their suspension.

Exclusion from school may involve suspension or expulsion. Exclusions affecting certain exceptional students shall be governed by *PA Code ss13.62 and 341.91* (relating to right to education and disciplinary exclusions of certain students with a disability from special education placement).

Suspension is exclusion from school for a period of one (1) to ten (10) consecutive school days. Suspensions may be imposed by the principal. No student shall be suspended until the student has been informed of the reason for the suspension and given an opportunity to respond. Prior notice of the intended suspension is not required when it is clear that the health, safety, and/or welfare of the school community is compromised.

The parents and the superintendent of the district shall be notified in writing when a student is suspended. When the suspension exceeds three (3) school days, the student and parent shall be given the opportunity for an informal hearing within five (5) days. Suspensions may not exceed ten (10) consecutive school days.

It is the student's responsibility to make up exams and other work missed while being disciplined by suspension. Make-up work must be:

- a. Student initiated within three (3) school days upon return;
- b. Completed within a reasonable time.

Students accumulating numerous suspensions will be referred to the school board for expulsion. Expulsion is exclusion from school by the Board of Education for a period exceeding ten (10) school days and may be permanent expulsion from the school roster. All expulsions require a prior formal hearing.

TAKE YOUR CHILD TO WORK DAY (204)

Students may participate in *Take Your Child To Work Day* (April) providing a valid excuse is submitted **prior** to the event. The absence will be excused with documentation from the parent's employer. This event will be considered an educational trip.

TARDINESS (204)

Tardy is defined as being delayed beyond the proper time. If a student is tardy, he/she must report to the office to be signed in. Students arriving late, **regardless of the reason**, will be marked tardy. Students arriving more than 1½ hours after the start of school, or leaving more than 1½ hours prior to dismissal time will be recorded as absent a half day. Students must attend school for at least five hours in order to be credited with a full day's attendance (2 ½ hours for half-day). Excessive tardiness interferes with the educational process and is strongly discouraged. The following consequences will be enforced for each occurrence of tardiness **WITHOUT A DOCTOR'S EXCUSE**:

- 0 to 4 – Warning
- 5 to 9 - Loss of recess
- 9 to 14- After school detention
- 15 or more- Legal action through the District Magistrate or Children and Youth

TEACHER REQUESTS

Parents are strongly discouraged from making requests for teachers unless there is a specific educational need to be considered. Teacher requests should be mailed, emailed, or hand-delivered to the principal by May 1st of each year for the upcoming school year. Teachers and administrators will not accept verbal requests or share requests with colleagues. Requests will not be guaranteed due to the various factors that we consider when making class lists. Your understanding and cooperation are greatly appreciated.

WITHDRAWAL FROM SCHOOL (208)

Parents should notify the school at least three (3) days in advance of impending transfers. They must complete a withdrawal form in the school office before the transfer takes place. This will provide a smooth transferring process. **ALL TEXTBOOKS,**

LIBRARY BOOKS, AND LUNCH PAYMENTS MUST BE CLEARED PRIOR TO THE TRANSFER OF ANY STUDENT RECORDS.

WELLNESS / GENERAL HEALTH INFORMATION

WELLNESS POLICY (246)

The Conemaugh Township Area School District recognizes that student wellness and proper nutrition are related to students' physical well-being, growth, development, and readiness to learn. The Board is committed to providing a school environment that promotes student wellness, proper nutrition, nutrition education, and regular physical activity as part of the total learning experience. A copy of the Wellness Policy is available upon request in the school office.

GENERAL HEALTH (200, 209)

Your child's health is extremely important. Consequently, we are asking for your cooperation and assistance with the following:

1. Check your child/children daily before they leave for school to be sure they are properly dressed for weather conditions.
2. Please keep your child home when they display signs of infectious illness (e.g., fever, vomiting). Children exhibiting these symptoms cannot function properly and could infect others.
3. Children must be **fever, diarrhea, and vomit free for a period of 24 hours** prior to returning to school following an illness.
4. State law requires that all students must have an up-to-date immunization record. This includes the following (Policy 209)
 - **Diphtheria and Tetanus** – Four or more properly spaced doses with a dose administered on or after the fourth birthday.
 - **Polio** – Three or more properly spaced doses
 - **Measles (Rubeola)** – Two properly spaced doses (preferably as MMR) with the first dose administered at 12 months of age or older.
 - **German Measles (Rubella)** - One dose (preferably as MMR) administered at 12 months of age or older.
 - **Mumps** – Two doses (preferably as MMR) administered at 12 months of age or older, or a physician diagnosis of mumps disease indicated by a written record signed by a physician.
 - **Hepatitis B** – Three properly spaced doses.
 - **Varicella (Chicken Pox)** – Two properly spaced doses or history of disease
5. All kindergarten students must have a physical and a dental examination prior to or during their kindergarten school year.
6. Parents are strongly urged to administer medication at home. Medication to be administered during school hours **MUST** be accompanied with a written order from the parent and/or family physician. The doctor's order must specify the medication, the dosage, and the time it is to be administered. Medication is to be brought to the school by the parent/guardian in its original container and will be kept in the health room. The school nurse will administer medication. Please refer to the **Requirement for Medication Administration by School Personnel** section.
7. The school nurse (or designated personnel) will administer first aid to students. In case of a serious accident or illness, school personnel will attempt to contact parents immediately. PLEASE be sure your child's Emergency Health History Card is kept current.
8. Students being sent home from school due to illness or injury will be released **ONLY** to parents or another properly identified/authorized adult. It is essential to have authorized adults' names and telephone numbers listed on the Emergency Card. Only the school nurse or principal have the authority to contact parents when a child is ill at school.
9. State law requires the following health services to be conducted during the school year.
 - a. Physical examination to students in kindergarten

- b. Dental examination to students in kindergarten and third grade
- c. Hearing screening to students in kindergarten, first, second, and third grade
- e. Vision screening to students in kindergarten through fifth grade
- f. Height and weight measurements and BMI (body mass index) calculation to students in kindergarten through grade 5

HIV/ AIDS (203)

District Policy 203.1 regarding HIV / AIDS is available upon request in the school office.

MEDICATION (District Policy #210)

For the health and safety of your child, a policy governing the administration of medication to pupils during school hours has been adopted. The district will cooperate with parents and their medical practitioners in **giving prescribed medications** when these must be taken **during school hours**.

Ideally, all medication should be given at home. It is also recognized at the present time many students are able to attend regular school because of the effectiveness of medication in the treatment of chronic disabilities and illness. The school nurse will be the primary person to administer or supervise the administration of **all** medication. **Any student who is required to take medication during the regular school day must comply with school regulations.** These regulations include the following:

I. PRESCRIPTION MEDICATION

For students on **temporary medication** such as antibiotics, etc., or **long-term medication**, such as asthma inhalers, the parents and students must comply with the following:

- ◆ **School officials must receive a written request from the physician stating that the medication is to be administered to the student.** Included in the request must be the name of the student, name of the medication, prescribed dosage, time to be administered, diagnosis, and possible side effects. Any special instructions should also be included.
- ◆ **Parent or guardian signature** requesting that medication be administered as prescribed by the physician is necessary. Permission forms can be obtained from the school nurse or from the District website. **The form must be completed and accompany the medication before it will be administered by the school nurse.**
- ◆ **All medication must be in the original prescription bottle with the current date and name of the student on the bottle.** Please ask your pharmacist to make up a **second bottle with the prescription label attached** so it may be kept at school. A refrigerator is available if needed.
- ◆ **All medication must be brought to the nurse's office or main office by a parent or guardian. No medication is to be kept in the student's possession.**

Note: An asthmatic inhaler and/or EpiPen may be kept in student's possession with prior approval from the nurse and a written order from the physician.

- ◆ The **school nurse has the right to call your physician** if there is a question. Physicians should be made aware of the problems associated with giving medications in school and arrange medication time intervals to avoid school hours whenever possible
- ◆ The parents must agree, in the form of the written instruction, to release the District and its employees from any liability as a result of the administration of medicine.

- ◆ Students in grades 3-12 will be responsible for coming to the office at the time medicine is to be given. In grades K-2 individualized plans will be made for the administration of medication by the nurse.
- ◆ The District retains the discretion to reject requests for administering medication.
- ◆ Prescription medication will be kept in a locked cupboard or refrigerator in the nurse's office.

II. NON-PRESCRIPTION MEDICATION

The **administration of non-prescription medication** is discouraged and can usually be avoided by adjusting the time schedule around school hours. Students **are not permitted to carry or dispense pills or any medication** during school hours. If it is absolutely necessary for a child to receive **non-prescription** during school hours, such as cold medicines, it will be **administered by the school nurse or other authorized personnel** under the following conditions:

- ◆ Any medication to be administered during the school day must be brought to the school by a parent or guardian.
- ◆ The parent or guardian must provide a written request from a physician for school personnel to administer any non-prescription medication not included in the District's standing orders. A complete list of these medications can be found on the student emergency card. A medication permission form can be obtained from the nurse's office or the District website. The form must be completed and accompany the medication before it will be administered by authorized personnel.
- ◆ Included within the request must be the name of the student, name of the medication, dosage and frequency of administration.
- ◆ All medication must be sent in the original container and be clearly labeled.
- ◆ Medication sent to school in envelopes or baggies **will not** be accepted.

III. VIOLATION OF POLICY

These regulations are for the safety and protection of all the students in the District. Your cooperation with these regulations will be appreciated. Violation of this policy will result in students being sent to the office and the following disciplinary options may apply: notification of parents, detention, suspension, or legal action.

PREVENTION, TREATMENT, AND DISTRICT POLICY OF HEAD LICE

The following information on head lice is being provided in response to questions often asked by parents.

CHARACTERISTICS OF HEAD LICE:

Head lice are small (2 - 3 mm long) grayish-tan insects, flattened in shape from top to bottom. They have no wings and **do not** jump or fly. During all stages of their life cycle, head lice feed on human blood. They are almost exclusively confined to the head region. Favorite hiding places include behind the ears and on the back of the neck, although they may be found almost anywhere on the hair of the scalp. Head lice grow in little round silver-white eggs (nits) which are attached to the hair shafts approximately ¼" – 2" from the scalp. These oval specks, similar in appearance to grains of sugar, are easier to spot than the lice themselves. Unlike dandruff, nits cannot be dislodged easily. The nits hatch in about a week and lice may live as long as 30 days.

TRANSMISSION:

Head lice are transmitted directly from one person to another or by contact with articles that have been used by an infested person (such as combs, brushes, hats, scarves, bedding, and upholstery). The presence of head lice does not indicate a lack of hygiene or sanitation practiced by the host. Since head lice are unable to fly or jump, they are unlikely to wonder far from the head. Head lice cannot survive more than a day or so off the human host.

DIAGNOSIS:

How do you know if your child has head lice? Intense itching of the scalp is a major symptom. Scratch marks or tiny bite marks on the neck and scalp may also be present. Occasionally, a bacterial infection may develop from scratching, and the lymph glands on the back of the neck may appear swollen. Direct inspection of the hair and scalp is the best way to detect the presence of nits and head lice.

TREATMENT:

When head lice are found, important treatment is started immediately. The hair must be washed with a special shampoo such as NIX, RID, A-200 PYRIMATE, etc. These products may be purchased over-the-counter in most drug stores. Package instructions should be carefully followed. Once the hair has been shampooed, it should be combed with a special fine-tooth nit removal comb. The nit combs are not always completely effective however, which makes it necessary to remove remaining individual nits with your fingernails. Since all nits are not always killed with a single shampoo, treatment should be repeated in 7 to 10 days.

Personal items such as clothing, bedding, towels, etc. should be machine washed in hot water and dried in a hot dryer for at least 20 minutes. Hats, stuffed animals, and other items that can't be washed should be dry cleaned (if possible), or sealed in plastic bags for two weeks. Combs and brushes should be soaked in hot water (130 F) for ten minutes. Carpets, pillows, mattresses, upholstered furniture, and car seats should be thoroughly vacuumed (BE SURE to discard bags from vacuuming promptly). Vacuuming will be as effective, and safer, than using pesticide sprays.

Remember to check your child's head regularly as a part of routine hygiene. If you have any questions, please do not hesitate to contact the school nurse.

LICE/NIT FREE PROCEDURE

- o Students will be sent home if lice or nits (eggs) are found in the student's hair. ANY STUDENT SENT HOME **MUST BE RE-EXAMINED BY THE SCHOOL NURSE AND/OR DESIGNEE *PRIOR TO RIDING THE SCHOOL BUS OR RETURNING TO SCHOOL***. Proof of treatment with a head louse shampoo (box top) must be presented at the time of the re-examination. The student must be free of all lice/nits or he/she will be sent home and not permitted to re-enter until all lice/nits are removed.

Parents will be notified in the form of a memo if the school nurse confirms the presence of nits or lice on any student(s) in your child's classroom. Additionally, all classroom furniture, including the coat rack, will be thoroughly cleansed and disinfected by the custodial staff.

COVID-19 HEALTH INFORMATION

In order to keep our students, staff, and families safe, the following health guidance and procedures are being provided:

- On a daily basis, families are asked to perform a symptom screening prior to arriving to the bus stop or school each day. Symptom screening includes:
 - Temperature of 100 degrees Fahrenheit or higher
 - Sore throat
 - New, uncontrolled cough that causes difficulty breathing (for students with chronic allergic/ asthmatic cough, a change in their cough from baseline)
 - Diarrhea, vomiting, or abdominal pain
 - Shortness of breath, difficulty breathing
 - New onset of severe headache, especially with a fever
 - Lack of taste or smell
 - Muscle pain/ache and/or fatigue

- If your child had close contact (within 6 feet of an infected person for at least 15 minutes) with a person with confirmed COVID-19, please contact your child's primary care physician for further guidance,
- If your child presents with fever, diarrhea, vomiting or other symptoms of concern and the nurse or designee contacts a parent to pick the child up, urgency is appreciated. Ill children will be secured in the nurse's suite until the parents arrive, preferably within an hour.

ELEMENTARY SCHOOL FLOOR PLAN

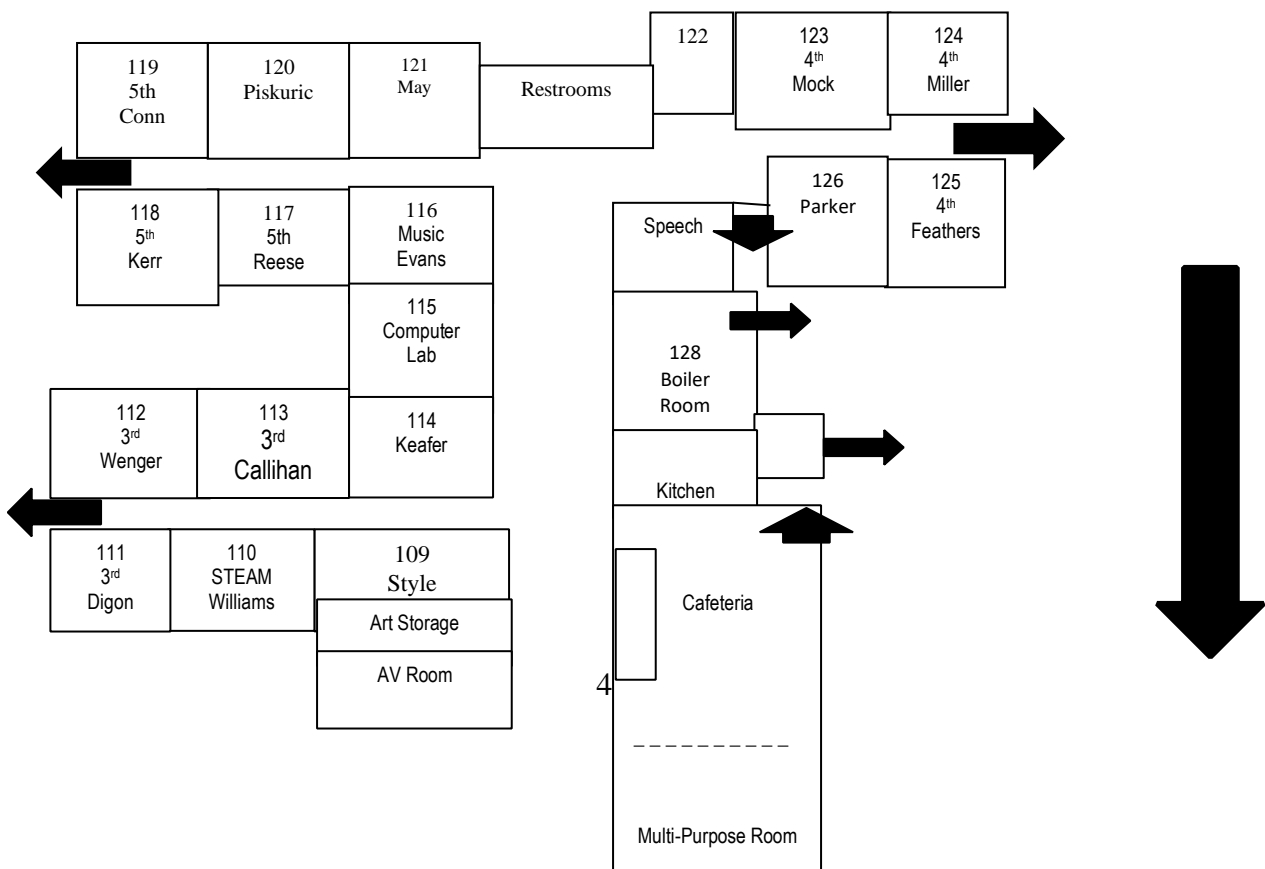

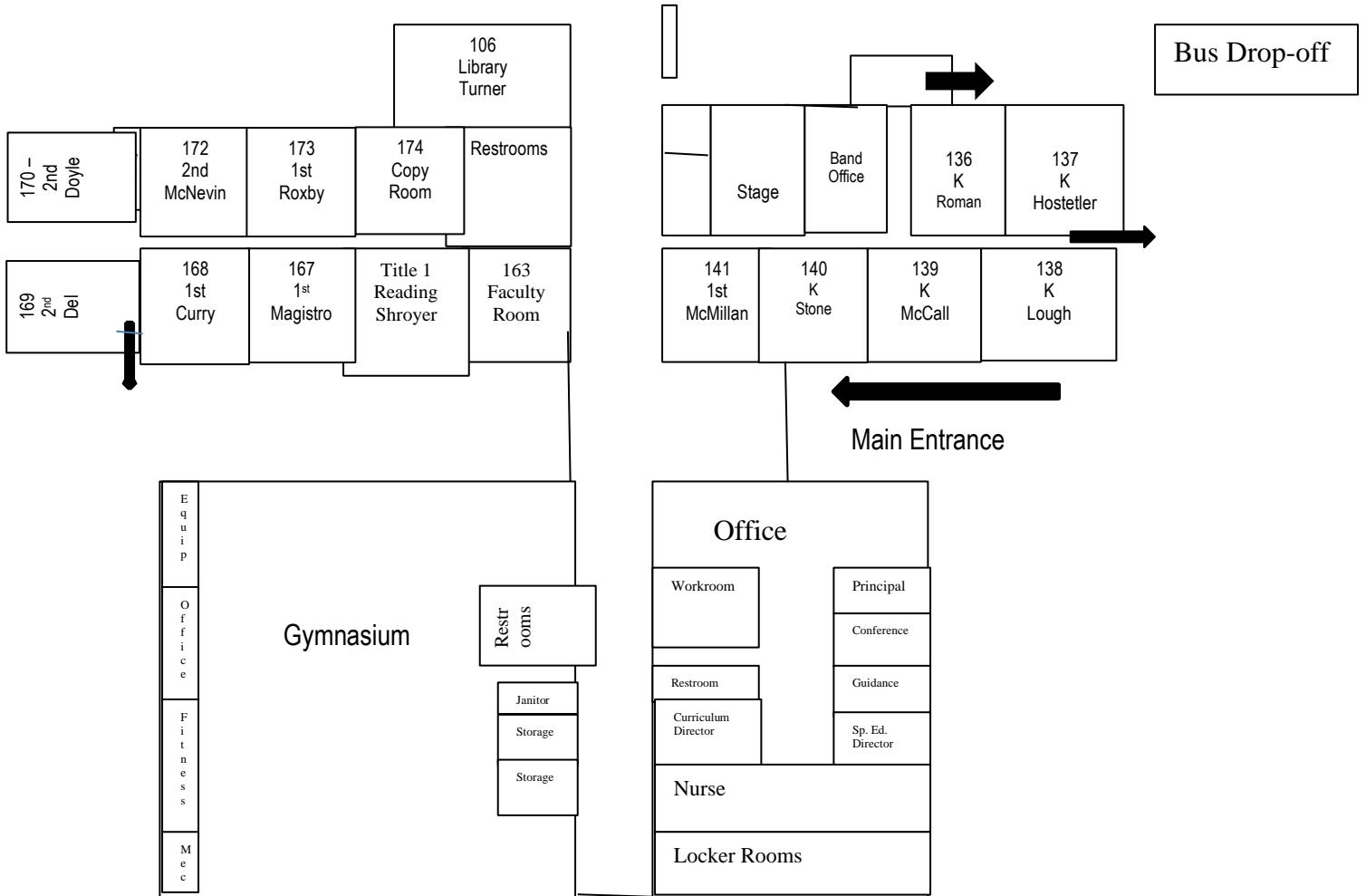

APPENDIX A

DISCIPLINARY STRUCTURE – STUDENT MISCONDUCT/RESPONSE

LEVEL I

DESCRIPTION OF BEHAVIOR

Level I misconduct involves behavior on the part of the student which impedes orderly classroom procedures or interferes with the orderly operation of the school.

These misbehaviors will be handled by an individual staff member. They should be dealt with consistently, swiftly, fairly, and without bias.

EXAMPLES

- Minor vandalism
- Inappropriate attire

- School tardiness
- Tardiness
- Failure to complete assignments or carry out directions
- Classroom/hall disturbances, writing/passing notes, gum chewing, teasing, taunting, loud noises, pushing, running, out of seat, etc.
- Not being prepared for class
- Sleeping
- Not having a hall pass
- Loitering in the hall
- Inappropriate remark

PROCEDURES

Each teacher is responsible for establishing individual classroom rules that are well understood by their students and consistent from day to day.

Immediate intervention is required by the staff member who is supervising the student or who observes the misbehavior.

It is suggested that teachers keep a daily log of the offenses incurred and disciplinary measures taken.

Repeated misbehavior may require a parent/teacher conference and/or parent conference with the counselor or principal.

DISCIPLINARY OPTIONS:

- Verbal reprimand
- Parent conference (person or phone)
- Withdrawal of classroom privileges - not to include restroom
- Behavior contract
- Counseling (after class with teacher)
- Time out area
- Sentences or essays
- Teacher-supervised detention (after school)

LEVEL II

DESCRIPTION OF BEHAVIOR

Level II misconduct involves behavior whose frequency or seriousness tends to disrupt the learning climate of the classroom or the school.

These infractions usually result from continuation of Level I misbehavior and require the intervention of personnel on the administrative level because the execution of Level I disciplinary response(s) has failed to correct the situation. Also included in this level are misbehaviors which do not represent a direct threat to the health and safety of others but whose educational consequences are serious enough to require corrective action on the part of the administrative personnel.

EXAMPLES

- Unmodified Level I behavior
- Excessive display of affection
- Failure to serve detention/suspension assignments
- Abusive or obscene language or gestures
- Bus disturbances
- Insubordination (refusal of student to do what he/she was told to do)
- Impersonation of parent/teacher, etc.
- Using forged notes/excuses/passes/tests
- Cheating
- Excessive Tardiness
- Leaving school without permission
- Gambling
- Possession / use of tobacco
- Instigating a fight
- Malicious horseplay/kicking/tripping/pushing
- Unauthorized use or possession of electronic equipment

PROCEDURES

A discipline log of the offense is recorded by the staff member and sent to the office with the student.

An administrator meets with the student and confers with the parent about the student misconduct and resulting disciplinary action.

A record of the offense and the disciplinary action is maintained by the administration. The teacher is informed of the administrator's action, verbally or on the bottom section of the teacher discipline log.

DISCIPLINARY OPTIONS

- Parent/staff conference
- Confiscation of equipment (radios, beepers, telephones, nuisance devices, etc.)
- Behavioral contract
- Social probation (dances, games, assemblies, etc.)
- Detention
- Required conference with the Guidance Counselor
- Referral for psychological evaluation
- Referral to outside agency
- Cancel bus privilege (for bus offenses)
- Modified school day (special situations/students)
- Suspension
- Student schedule change
- Loss of pass privileges
- Cheating - 0 score on assignment, test or quiz

LEVEL III

DESCRIPTION OF BEHAVIOR

Level III misconduct involves acts directed against persons or property, and whose consequences may endanger the health or safety of others in the school.

Those acts which are criminal (or illegal) will automatically be referred to the appropriate law enforcement office.

EXAMPLES

- Unmodified Level I or Level II behavior
- Harassment, bullying, hazing
- Behavior which may result in a serious injury
- Fighting (altercation)
- Theft/possession/sale of stolen property
- Possession/furnishing/selling of fireworks/firecrackers, etc.
- Abusive or obscene language or gestures to staff
- Defiance/threatening staff
- Threats to others
- Extortion
- Reckless driving on school property

PROCEDURES

A discipline log of the offenses is recorded by the staff member and sent to the office with the student.

An administrator meets with the student and confers with the parent about the student misconduct and the resulting disciplinary action.

A record of the offense and the disciplinary action is maintained by the administration. The teacher is informed of the administrator's action, verbally or on the bottom half of the teacher's discipline log.

DISCIPLINARY OPTIONS

- Parent conference and/or hearing
- Detention
- Suspension
- Required conference with the guidance counselor
- Referral for psychological evaluation
- Temporary or permanent removal from class
- Charges under the Pennsylvania Civil or Criminal Code or local ordinances
- Suspension of driving privileges on campus

LEVEL IV

DESCRIPTION OF BEHAVIOR

Level IV misconduct involves acts which result in violence to another person or property, or which pose a direct and serious threat to the safety of others in the school.

EXAMPLES

- Major vandalism
- Possession/use/transfer of dangerous weapons
- Possession/use/transfer/intent to sell/selling of unauthorized substances (drugs/alcohol/etc.)
- Bomb/fire threat or false alarm
- Assault and/or battery
- Arson
- Physically assaulting a staff member
- Using fireworks/firecrackers, etc.

PROCEDURES

A discipline log of the offenses is recorded by the staff member and sent to the office with the student.

An administrator meets with the student and confers with the parent about the student misconduct and the resulting disciplinary action.

A record of the offense and the disciplinary action is maintained by the administration. The teacher is informed of the administrator's action, verbally or on the bottom half of the teacher's discipline log.

School officials may contact law enforcement and assist in prosecuting the offender.

A complete and accurate report is submitted to the Superintendent.

Should a staff member be assaulted, expulsion procedures **shall** be initiated and criminal charges **may** be filed by the school district and the individual staff member.

DISCIPLINARY OPTIONS

- Parent hearing
- Referral for psychological treatment
- All proven offenses in Level IV will have a mandatory suspension, with an informal hearing
- Suspension\Expulsion
- Other Board action which results in appropriate placement
- Charges under the Pennsylvania Civil Criminal Code or referral to appropriate law enforcement agencies



Acceptable Use Policy In Accordance With Board Policy #815

The purpose of this policy is to outline the acceptable uses of technology, including but not limited to hardware devices, software, network and Internet access in the Conemaugh Township Area School District and to define the consequences of misuse. All technology in the Conemaugh Township Area School District has been purchased and installed for instructional and administrative use only. The software installed on each computer and network has been purchased by the district and licensed for use herein. The purpose of all district software, Internet sites, and e-mail is to support research and education. Because the technology, tablets, ipads and Chromebooks are used in a variety of classroom situations, it is critical that each device operates to support research and education. Even though the school district makes a “best” effort to filter/block/detect access to non-educational websites and monitor Internet traffic, student usage of these websites at any time would be classified as “inappropriate usage” of the technology and/or internet resource.

All users must read, sign and return the appropriate acceptable use acknowledgement form before being granted access to district technology. Students will sign as well as obtain their parent/guardian signature and return the appropriate form to their teachers.

Basic Guidelines for Technology Usage

1. All students must have a signed permission slip from their parents that authorizes them access to technology and the Internet.
2. Respect for the equipment of the school and its network is a condition for use of the technology.
3. Students are never to give anyone their password to any of their accounts or allow another student to use their account to access the Internet or school network.
4. Students are not to give out personal information like telephone number, full name, address, etc. to anyone on the Internet.
5. Students are to notify the teacher/librarian immediately of any disturbing material they may encounter on the web or in e-mail. Social media sites have been blocked by the district. Students are prohibited from using any type of social media (examples - Facebook, Twitter, SnapChat..) on any electronic device (desktop, laptop, tablet, cell phone).
6. Students may not download any programs from the Internet on any device (cell phone, laptop, tablet, cell phone).
7. Students will not bring food or drinks into the lab.
8. Materials created and /or stored on the network are not guaranteed to be private. Network administrators may review the system from time to time and delete unnecessary files.

Student Use of Personal Devices

Unacceptable Uses

1. The network may not be used to download, copy, or store any software, shareware, or freeware including, but not limited to games, music, pictures, without prior permission from the network administrator.
2. The network users may not use vulgar, derogatory, or obscene language. Users may not engage in personal attacks, harass another person, or post private information about another person.
3. Network users may not log on to someone else's account or attempt to access another user's files. "Hacking" or otherwise trying to gain access to another person's or organization's computer system is prohibited.
4. Network users may not access Web sites, newsgroups, or chat areas that contain material that is obscene or that promotes illegal acts. If a user accidentally accesses such information, he or she should immediately notify a teacher, librarian and/or network administrator.

- a. Students may not check personal email accounts, or personal webpages.
- b. No pictures may be downloaded or uploaded to computers by students without permission.

5. The network may not be used for any activity, or to transmit any material that violates United States or local laws. This includes, but is not limited to illegal activities such as threatening the safety of another person, violating copyright laws, or engaging in "spamming" (sending unwanted junk email to 10 or more email users, including, but not limited to pornography, chain letters, advertising, etc).

6. The network may not be used for commercial purposes. Users may not buy or sell products or services through the system without prior permission from the network administrator.

7. Use of the network for advertising or political or religious lobbying is prohibited.

8. Any user identified as a security risk or having a history of problems with District owned technology may be denied access. The building administrator shall have the final authority to determine what inappropriate use is.

Student's Name (printed clearly) _____

Parent/Guardian Signature _____

Parent/Guardian E-Mail _____

Children's Internet Protection Act: Internet Safety Policy

It is the policy of Conemaugh Township Area School District to: (a) prevent, to the extent practical, user access or the transmission over its computer network, of inappropriate material via Internet, electronic mail, or other forms of direct electronic communications; (b) prevent, to the extent practical, unauthorized access and other unlawful online activity; (c) prevent, to the extent practical, unauthorized online disclosure, use, or dissemination of personal identification information of minors; and (d) comply with the Children's Internet Protection Act [Pub. L. No. 106-554 and 47 USC 254(h)].

Conemaugh Township Area Elementary School

Legally Excused Absence Request



Dear Parent or Guardian:

This letter and form are in accordance with the district's attendance policy as stated in the board policy manual and the student handbook. It is the policy of this school that students who take time off during school hours are required to submit in writing the dates and reason of time off to the school principal **at least one week prior to the absence.** Students may use up to three educational experience days per year that will be considered excused. Students who take time off during school hours do so with the full understanding that they are responsible for the work covered during their absence. **Students must arrange with teachers to obtain school work prior to the absence.** The work must be made up in a reasonable amount of time and may require completion in school, which may necessitate the loss of recess time. Your cooperation is greatly appreciated.

Mrs. Nicole Dull

Elementary School Principal

Student's Name _____ Grade _____

Dates of Absence: from _____ to _____

Please check one:

_____ Participation in 4H/FFA project (counted as a parent written excuse)

_____ Observance of a religious holiday (counted as a parent written excuse)

_____ Participation in National Veterans' Organization (counted as an educational experience, if documentation from Veterans' Organization is provided confirming visit on that day.)

_____ Non-school sponsored educational experience (max. 3 days, counted as an educational experience)

List the destination and content of the educational experience:

Parent's Signature _____ Date _____

For office use only:

Principal's Approval _____ Date _____

Absences will be categorized as:

Date(s) _____

Type

_____ Parent Written Excuse(s)

_____ Educational Experience Day(s)

___ Unexcused Absence(s)

Date(s) _____

Type

___ Parent Written Excuse(s)

___ Educational Experience Day(s)

___ Unexcused Absence(s)

Date received _____

Copies sent to _____

Updated July 2020